

1. Introduction

1.1 Overview

ADL Embedded Solutions Military Class 2.5" SATA III SSD (Solid State Drive) is a high performance and high reliability storage device based on NAND Flash technology that is designed to solve the "bottlenecking" of a computing system by traditional hard disk drives. With zero moving parts, the 2.5" SATA III SSD has the same host interface and physical dimensions as a hard disk drive. With high performance and low power consumption, ADL Embedded Solutions 2.5" SATA III SSD can store a large amount of data for many different operating systems without the large footprint and weight.

ADL Embedded Solutions Military Class 2.5" SATA III SSD provides protection against shock and vibration that are common in extreme environments. ADL Embedded Solutions 2.5" SATA III SSD also contains a highly advanced flash memory management algorithms to guarantee higher performance and data integrity.

1.2 Features

Performance

- Host Interface: Serial ATA interface of 6 Gbps
- ATA-8 standard compliant including ATA8-ACS2
- Sequential Data Read/Write(max): 520/500MB/s*
- Sustained Data Read/Write (@32K block): 500/110MB/s**
- Form factor: 2.5" (100.00 X 69.85 X 9.50)mm
- Density: 32GB~640GB
- Input voltage: +5VDC, ±5%
- Operating temperature range
Commercial: 0°C to 70°C, Industrial: -40°C to +85°C
- Flash management algorithm: static and dynamic wear-leveling, bad block management algorithm
- Supports dynamic power management and SMART (Self-Monitoring, Analysis and Reporting Technology)
- ECC (Error Correction Code): 64 bit BCH ECC per 1KByte
- Read endurance: unlimited
- Data retention: 10 years
- MTBF: 3,000,000 Hours
- SLC NAND
- Secure Erase
- Military Erase
- Hardware Erase
- Write Protect
- Additional PCB mount to minimize shock & vibration
- Thicker gauge casing for ruggedized application
- AES256 and AES128 Encryption
ECB/CBC mode support
Mode0: Drive Generated Key
Mode1: Programmable Key



Hyperboloid Connector:

- Hyperboloid Contacts
- Immune to Shocking and Vibration
- Positive mating action
- Low electrical resistance
- Up to 100,000 Insertion
- Insertion/Extraction force, <1,00Z (28 gms) nominal per contact
- Mates with M4075-15S-7S, from mFactors.com

***Configuration Dependent**

**** Based on 80GB MLC**

Designed to MIL STD 810G

2. Military Erase Protocols Support:

1. DOD NISPOM 5220.22-M
2. DOD NISPOM 5220.22-M Supplement 1
3. NSA/CSS 9-12
4. NSA/CSS 130-2
5. ARMY AR 380-19
6. NAVSO P-5239-26
7. AFSSI-5020
8. IRIG 106-07

3. Supported SSD Capacity

SSD Capacity (Unformatted)	User-Addressable Sectors (Unformatted)
32GB	62,531,199
64GB	125,043,327
80GB	156,299,391
128GB	250,067,583
160GB	312,579,711
256GB	500,116,095
320GB	625,140,351
512GB	1,000,213,119
640GB	1,250,261,631

4. Functional Block Diagram

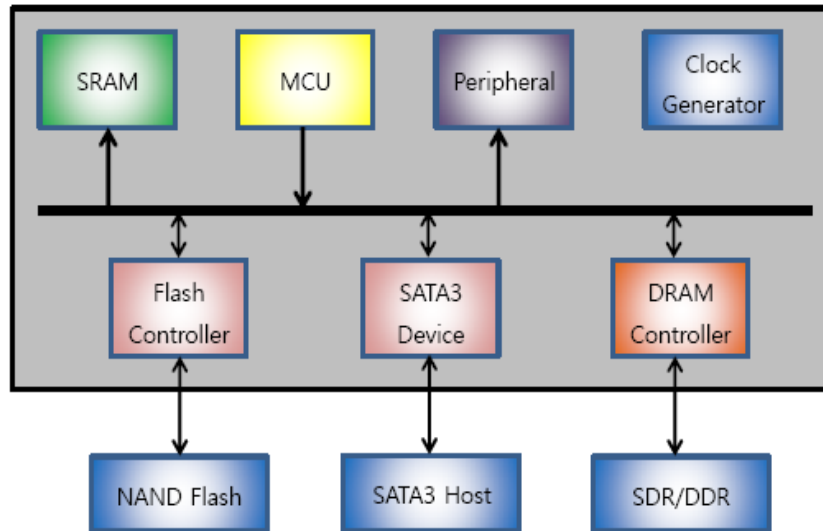

5 Environment Specifications

Environmental Specifications

Features	Operating	Non-operating
Temperature	Commercial: 0°C ~ 70°C	-55~95°C
	Industrial: -40°C ~+85°C	
Humidity	0~95° RH	
Vibration	MilStd 810G, 514.6 Simulated helicopter vibration, UH60. 1 hour per axis. Operational 20G Peak,10~2000Hz,(15mins/Axis) x3 Axis	
Shock	Terminal Saw-tooth, 20G, 15msec 1 pulse in each direction for each axis. Operational	
Altitude	80,000 feet for 4 hours while operating.	
IP Rating	N/A	

5.1 Power Specification

Recommended DC Operating Voltage: 4.75 ~5.25V

Power Consumption

Parameter		Typical	Unit
Standby		0.5	W
Idle		0.5	W
4KByte Sample Data	Seq uential Read	1.15	W
	Sequential Write	1.0	W
	Random Read	2.0	W
	Random Write	2.0	W
512KByte Sample Data	Sequential Read	1.15	W
	Sequential Write	1.3	W
	Random Read	2.0	W
	Random Write	2.0	W

5.2 Reliability Specification

Wear-leveling

ADL Embedded Solutions 2.5" SATA III SSD support both static and dynamic wear-leveling. These two algorithms guarantee all types of flash memory at the same level of erase cycles to improve lifetime limitation of NAND based storage.

ECC

ECC (Error Correction Code): 64bit BCH ECC per 1KByte

Bad block management algorithm

This algorithm replaces bad blocks with new ones from available spares on media error conditions.

MTBF

MTBF (Mean Time between Failures) of ADL Embedded Solutions 2.5" SATA III SSD: 3,000,000 hours*

*Ground benign @25°C, Tekcirdia SR-332

Data retention

Data retention at 25°C of ADL Embedded Solutions 2.5" SATA III SSD: 10 years

6. SATA interface signals and connector pins

The connector on ADL Embedded Solutions SSD is divided into a signal segment and a power Segment. The following tables summarize the signals on the SATA interface connector. For a detailed description of these signals, refer to the Draft ATA-8 Standard.

6.1 Signal Segment Pin-out Configuration

Pin Configuration

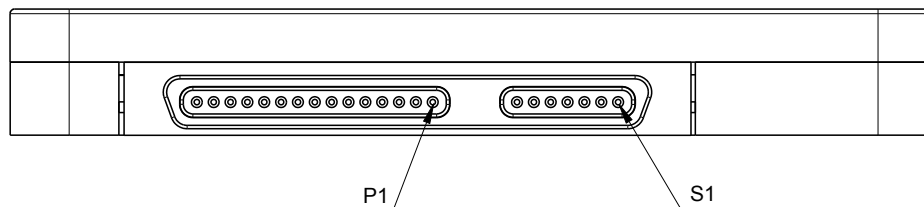

Figure 1: Connector View

SATA Connector Signal Definitions

Pin	Signal Name	Signal Definitions
S1	Ground	Second Mate
S2	R+	+Differential Receive Signal
S3	R-	- Differential Receive Signal
S4	Ground	Second Mate
S5	T-	-Differential Transmit Signal
S6	T+	+Differential Transmit Signal
S7	Ground	Second Mate

6.2 Power Segment Pin-out Configuration

The SATA power connector consists of 15 pins. The following table lists the single definitions of the 15-pin segment.

SATA Connector Power segment Definitions

Pin	Signal name	Signal Definitions
P1*	NC/ Optional Features	1, 2, 3, 4
P2*	NC/ Optional Features	2, 3, 1, 4
P3*	NC/ Optional Features	3, 1, 2, 4
P4	Ground/ Optional Features	2, 8
P5	Ground	First Mate
P6	Ground	First Mate
P7	V5	5V Power, pre-charge, Second Mate
P8	V5	5V Power
P9	V5	5V Power
P10	Ground	Second Mate
P11	Ext Trigger	Military Erase
P12	Ground	First Mate
P13*	LED+	5
P14*	IC ² CLK	6
P15*	IC ² Data	7

Note:

* Pin1, Pin2, Pin3, Pin13, Pin14, Pin15 have been reassigned to enhance the SSD's capability. They will remain NC until the feature is enable.

1. Bus Status Erase
2. Ext Trigger
3. Write Protect
4. Data Activity
5. Led Source & Current (3.3V/330 Ω)
6. I2C Clock
7. I2C DATA Not used
8. Ground

7. Supported ATA Command Lists

Supported ATA8 standard including ATA-ACS2.

Command Name	Command Code (Hex)	Command Name	Command Code (Hex)
Check power mode	E5h or 98h	Set transfer mode	EFh/03h
DEVICE RESET	08h	Enable Power-Up In Standby	EFh/06h
DEVICE CONFIGURATION	-	Disable Power-Up In Standby	EFh/86h
DEVICE CONFIGURATION FREEZE LOCK	B1h/C1h	Enable DMA Setup FIS Auto-Activate optimization	EFh/10h/02h
DEVICE CONFIGURATION IDENTIFY	B1h/C2h	Disable DMA Setup FIS Auto-Activate optimization	EFh/90h/02h
DEVICE CONFIGURATION RESTORE	B1h/C0h	Enable Device-initiated interface power state transitions	EFh/10h/03h
DEVICE CONFIGURATION SET	B1h/C3h	Disable Device-initiated interface power state transitions	EFh/90h/03h
DOWNLOAD MICROCODE	92h	SET MAX	-
DATA SET MANAGEMENT	06h	SET MAX ADDRESS	F9h/na
EXECUTE DEVICE DIAGNOSTIC	90h	SET MAX FREEZE LOCK	F9h/04h
FLUSH CACHE	E7h	SET MAX LOCK	F9h/02h
FLUSH CACHE EXT	EAh	SET MAX SET PASSWORD	F9h/01h
IDENTIFY DEVICE	ECh	SET MAX UNLOCK	F9h/03h
IDLE	E3h or 97h	SET MAX ADDRESS EXT	37h
IDLE IMMEDIATE	E1h or 95h	SET MULTIPLE MODE	C6h
INITIALIZE DEVICE PARAMETERS	91h	SLEEP	E6h or 99h
NOP	00h/00h	SMART	-
READ BUFFER	E4h	SMART DISABLE OPERATIONS	B0h/D9h
READ DMA	C8h	SMART ENABLE OPERATIONS	B0h/D8h
READ DMA EXT	25h	SMART ENABLE/DISABLE ATTRIBUTE AUTOSAVE	B0h/D2h
READ FPDMA QUEUED	60h	SMART EXECUTE OFF-LINE IMMEDIATE	B0h/D4h
READ LOG EXT	2Fh	SMART READ ATTRIBUTE THRESHOLDS	B0h/D1h
READ MULTIPLE	C4h	SMART READ DATA	B0h/D0h
READ MULTIPLE EXT	29h	SMART READ LOG	B0h/D5h
READ NATIVE MAX ADDRESS	F8h	SMART RETURN STATUS	B0h/DAh
READ NATIVE MAX ADDRESS EXT	27h	SMART SAVE ATTRIBUTE VALUES	B0h/D3h
READ SECTOR(S)	20h	SMART WRITE LOG	B0h/D6h
READ SECTOR(S) EXT	24h	STANDBY	E2h or 96h
READ VERIFY SECTOR(S)	40h	STANDBY IMMEDIATE	E0h or 94h
READ VERIFY SECTOR(S) EXT	42h	SOFT RESET	FFh
SECURITY DISABLE PASSWORD	F6h	WRITE BUFFER	E8h
SECURITY ERASE PREPARE	F3h	WRITE DMA	CAh
SECURITY ERASE UNIT	F4h	WRITE DMA EXT	35h
SECURITY FREEZE LOCK	F5h	WRITE FPDMA QUEUED	61h
SECURITY SET PASSWORD	F1h	WRITE LOG EXT	3Fh
SECURITY UNLOCK	F2h	WRITE MULTIPLE	C5h
SEEK	70h	WRITE MULTIPLE EXT	39h
SET FEATURES	-	WRITE SECTOR(S)	30h
Enable write cache	EFh/02h	WRITE SECTOR(S) EXT	34h
Disable write cache	EFh/82h	VENDOR SPECIFIC CMD	FEh

8. Product Specifications

8.1 Physical Specifications

Physical dimension and weight

Model	Length(mm)	Width(mm)	Height(mm)	Weigh(g)
32GB-640GB	100.45 ±0.25	69.85 ±0.25	9.50 ±0.20	124

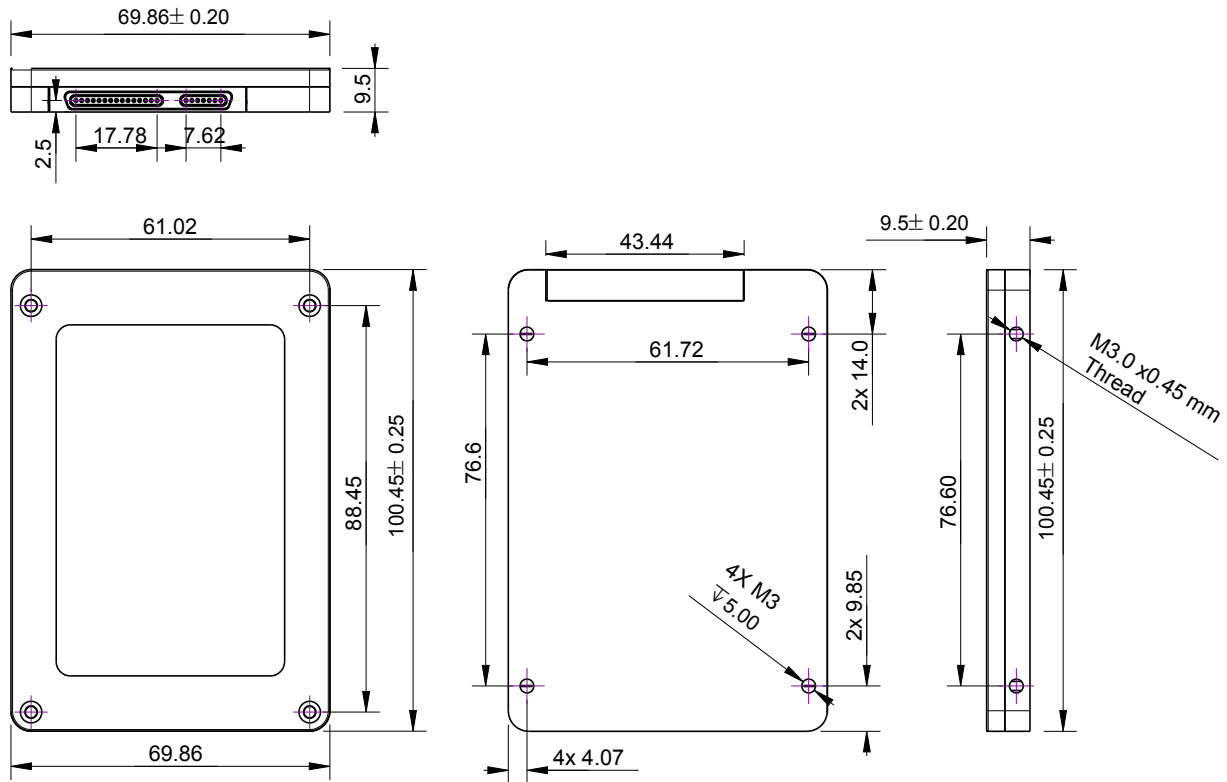

Figure 2: Top and bottom View

This datasheet is to be used as a guideline and reference only. Its characteristics are based on similar known good product and might not reflect the actual product performance. ADL Embedded Solutions makes every effort to ensure that the datasheet is accurate as possible, and has the right to make any changes without notice.

HISTORICAL CONTROL LOG

Part Number	Revision		Description	Effective Date
	was	is		
MIL-STD 810, 2.5" SLC SATA	---	1.0	Initial Release	3/17/16

Corporate Headquarters

ADL Embedded Solutions Inc.
4411 Morena Blvd. Suite 101
San Diego, CA 92117-4345
T: 858-490-0597
F: 858-490-0599
sales@adl-usa.com
support@adl-usa.com
www.adl-usa.com

European Headquarters

ADL Embedded Solutions GmbH
Eiserfelder Straße 316
D-57080 Siegen, Germany
T: +49 (0) 271 250 810 0
F: +49 (0) 271 250 810 20
sales@adl-europe.com
support@adl-europe.com
www.adl-europe.com