

HPSC104-SER Manual

High Power & Smart Charging Vehicle Power Supply DC to DC Converter

Manufactured by
TRI-M ENGINEERING

Engineered Solutions for Embedded Applications

Technical Manual

P/N: HPSC104-SER V3-MAN

Revision: 11-January-2010

TRI-M ENGINEERING

1407 Kebet Way, Unit 100
Port Coquitlam, BC V3C 6L3
Canada

<http://www.Tri-M.com>

Tel 604.945.9565

North America 800.665.5600

Fax 604.945.9566

Table of Contents

CHAPTER 1 - INTRODUCTION 4

 1.1 GENERAL DESCRIPTION 4

 1.2 FEATURES 5

 1.3 SPECIFICATIONS 6

CHAPTER 2: CONFIGURATION AND INSTALLATION 7

 2.1 Introduction 7

 2.1.1 Main Input Power Connector 8

 2.1.2 Output Power Connector 8

 2.1.3 Battery Connector 8

 2.1.4 Aux Battery Connector 9

 2.1.5 RS232 Serial Port Interface 9

 2.1.6 Control I/O Connector 10

 2.2 Jumper Selection 10

 2.2.1 Interrupt Service Request Jumpers 10

 2.2.2 PC/104 Memory Mapped Address Jumper 10

PREFACE

This manual is for integrators of applications of embedded systems. It contains information on hardware requirements and interconnection to other embedded electronics.

DISCLAIMER

Tri-M Engineering makes no representations or warranties with respect to the contents of this manual, and specifically disclaims any implied warranties of merchantability or fitness for any particular purpose. Tri-M Engineering shall under no circumstances be liable for incidental or consequential damages or related expenses resulting from the use of this product, even if it has been notified of the possibility of such damages. Tri-M Engineering reserves the right to revise this publication from time to time without obligation to notify any person of such revisions. If errors are found, please contact Tri-M Engineering at the address listed on the title page of this document.

COPYRIGHT © 2006-06-07 TRI-M ENGINEERING

No part of this document may be reproduced, transmitted, transcribed, stored in a retrieval system, or translated into any language or computer language, in any form or by any means, electronic, mechanical, magnetic, optical, chemical, manual, or otherwise, without the express written permission of Tri-M Engineering.

CHAPTER 1 - INTRODUCTION

1.1 GENERAL DESCRIPTION

The HPSC104-SER is a high power, high performance DC to DC converter that supplies +5V, -5V, +12V, -12V and V5Sby (5V standby) outputs. The HPSC104-SER also includes a flash based microcontroller that supplies advanced power management, smart battery charger, PC/104 I/O memory mapped interface and an RS232 serial port. The HPSC104-SER is designed for low noise embedded computer systems, has a wide input range of 6-40V(>6:1) and is ideal for battery or unregulated input applications. The HPSC104-SER is specifically designed for vehicular applications and has heavy-duty transient suppressors (9000W) that clamp the input voltage to safe levels, while maintaining normal power supply operation.

The HPSC104-SER is a state-of-the-art Mosfet based design that provides outstanding line and load regulation with efficiencies up to 90 percent. Organic Semiconductor Capacitors provide filtering that reduces ripple noises below 20mV. The low noise design makes the HPSC104-SER ideal for use aboard aircraft or military applications or wherever EMI or RFI must be minimized.

The HPSC104-SER provides up to four stages of battery charging and can charge Lead-Acid, NiCd, and NiMh batteries and is also SMBus level 3 compatible. Charge currents are up to 4A, and battery charging voltages from 10 to 35V.

The HPSC104-SER has advanced power management functions that allows timed on/off control of the HPSC104-SER, notification of changes to main power and changes in the battery status. For example, the HPSC104-SER can be programmed to power off the outputs in 60 seconds, and then turn on again 12 hours later.

The HPSC104-SER size is 3.55 x 3.775 inches, and is a fully PC/104 compliant power supply. All generated voltages are provided to a removable "pluggable" header. A removable plug allows the HPSC104-SER to be easily installed. The RS232 serial port is provided on a standard DB9 connector.

The HPSC104-SER can be configured to meet almost any power supply and battery charging need for embedded applications, whether that be a simple +5V application, or providing power for back lighted LCD panels, or a full UPS (un-interruptible power supply configuration).

1.2 FEATURES

- DC to DC converter for embedded applications.
- “Load Dump” transient suppression on input power supply.
- Operates from 6VDC to 40VDC input.
- PC/104 compliant.
- PC/104 memory mapped interface and RS232 serial port for setup, monitoring and control.
- 5V, 12V, -12V, -5V, V5SBY and battery charger outputs.
- Temperature range -40 to 85C.
- Monitors up to 8 external temperatures using I2C digital temperature sensors.
- Optocoupled inputs for ignition, and system "shut-down" pushbutton.

All dimensions in mils unless otherwise stated
(1000 MILS = 1 INCH)

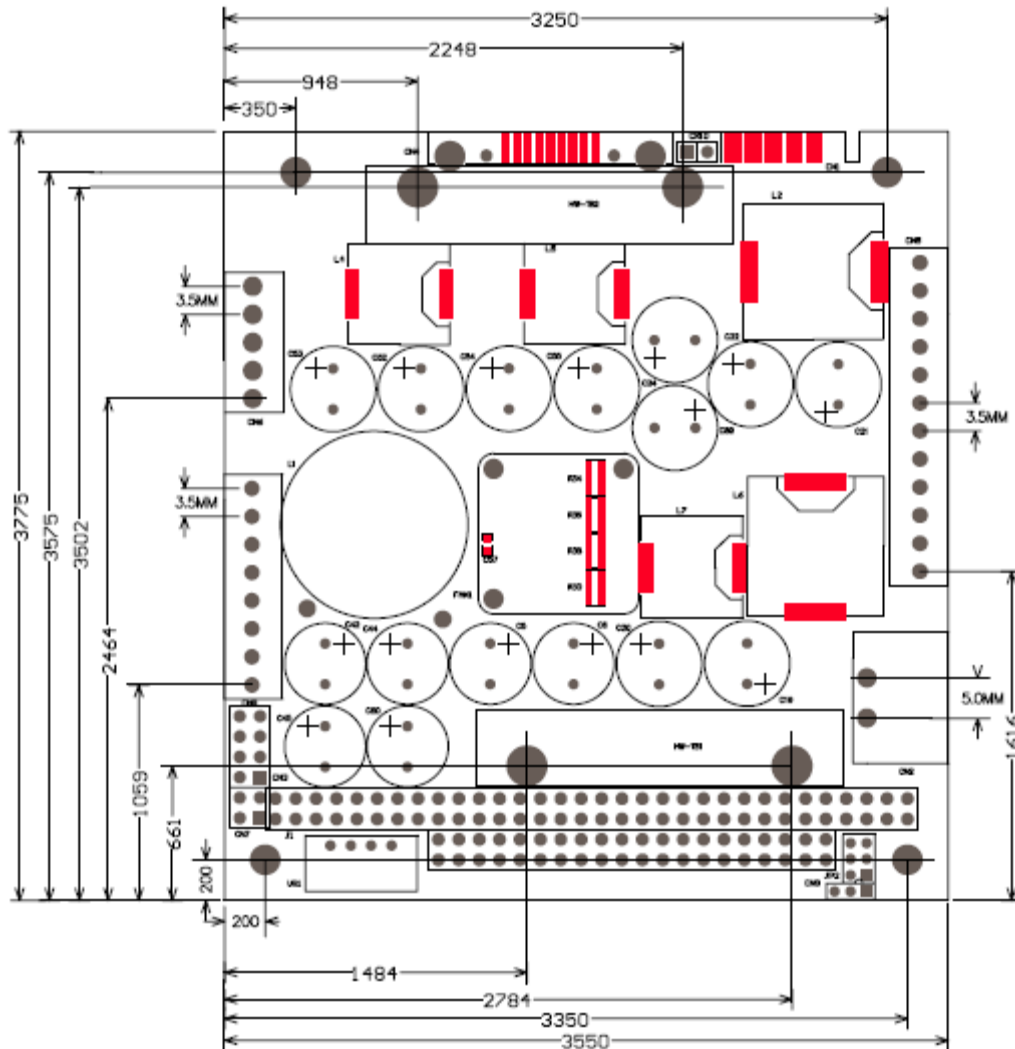

1.3 SPECIFICATIONS

Power Supply Specifications	
Model	HPSC104-SER
5V output (Includes current supplied to 12V, -12V & -5V regulators)	25A
12V output	5A
-5V output	400mA
-12V output	500mA
V5SBY	7A
Maximum battery charger current	4A
Battery Charger output voltage range	10 to 35V
Input voltage range	6-40VDC
Load regulation	<60mV
Line regulation	±40mV
Output temp drift	<40mV
Switching frequency (5V, 12V, -12V & 5VSBY)	310 to 320kHz
Output ripple	<20mV
Conducted Susceptibility	>57db
Efficiency	up to 95%
Temp range**	-40 to 85C
Size, PC/104 form factor compliant	3.55"W x 3.775"L x 0.6"H

*Measured on the 5V output.

** Temperature range as measured on the product heat sink.

CHAPTER 2: CONFIGURATION AND INSTALLATION

2.1 Introduction

This chapter describes the configuration and installation of the HPSC104-SER power supply. In addition, section 2.2 provides a formula to calculate the available +5VDC. Figure 2-1 shows the HPSC104-SER connectors, jumpers and other options.

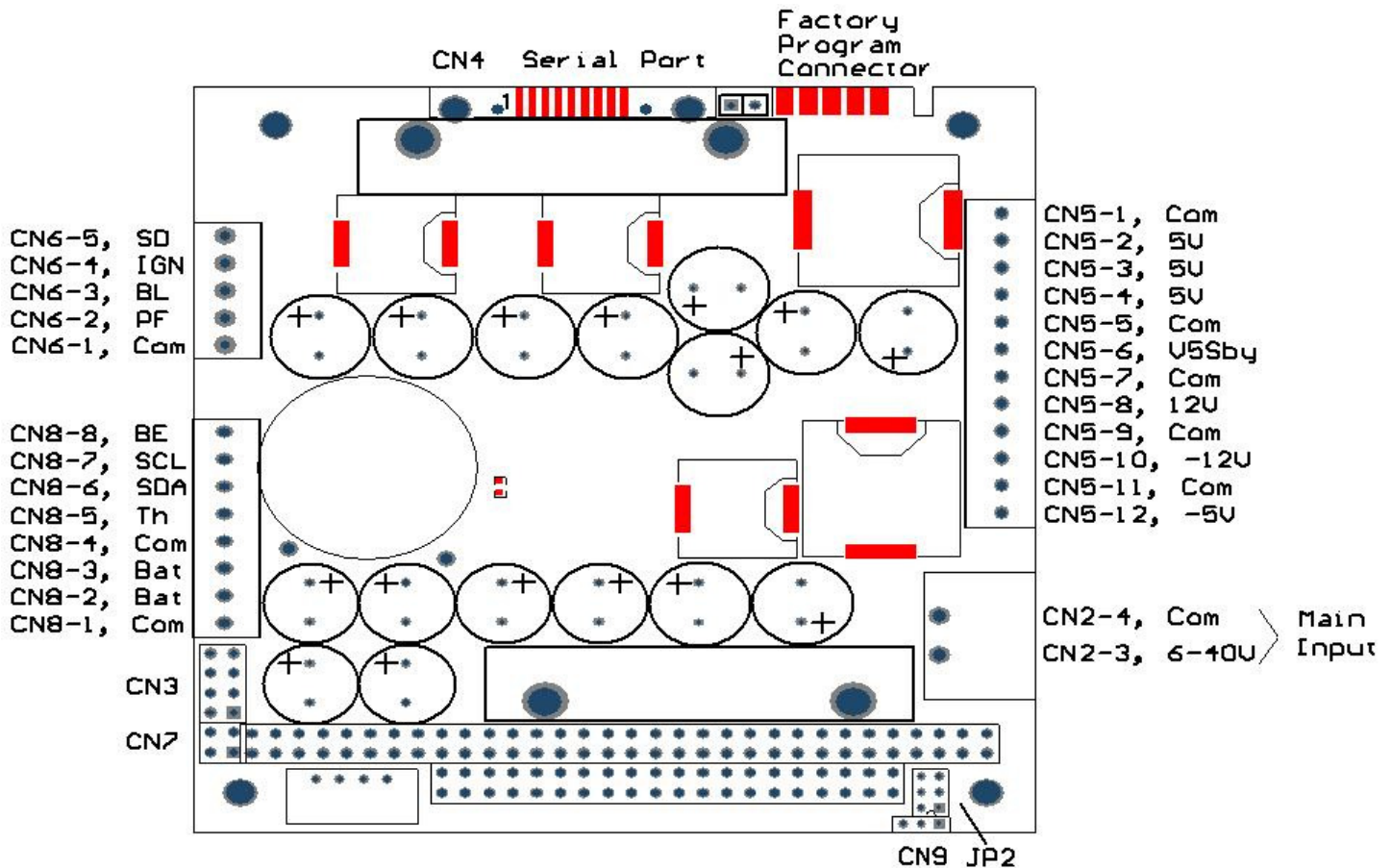

Power Considerations.

The +5V switching regulator is rated at 25A maximum output, however the +5V output supplies power to the +12, -5, and -12VDC regulators. To obtain the usable range of +5V output, “derate” according to the use of +12, -5, and -12VDC. Use the following formulae to calculate the maximum usable output.

$$Usable +5Voutput = 25A - \frac{(I[-5] + I[-12] * 2.4 + I[12] * 2.4)}{0.9}$$

Where: I[-5] = -5VDC current load
 I[-12] = -12VDC current load
 I[12] = 12VDC current load

Assuming 90 percent converter efficiency (actual efficiency may vary).

2.1.1 Main Input Power Connector

Input power is connected to the HPSC104-SER by a removable pluggable CN2. The power supply accepts DC input voltages in the range of 6VDC to 40VDC.

Unregulated vehicle power is connected as follows:

- Terminal 1: "hot" polarity
- Terminal 2: Common (0VDC)

2.1.2 Output Power Connector

Output power is available for use via removable pluggable connector CN5.

- CN5-1: Common
- CN5-2: +5VDC output
- CN5-3: +5VDC output
- CN5-4: +5VDC output
- CN5-5: Common
- CN5-6: V5Sby (5V standby)
- CN5-7: Common
- CN5-8: 12VDC output
- CN5-9: Common
- CN5-10: -12VDC output
- CN5-11: Common
- CN5-12: -5V output * The -5V output is produced with a "charge pump" converter manufactured by C&D part number NML0505S. A minimum load of 1kohm between CN5-12 and CN5-11 may be necessary to maintain the -5V without the components specified levels.

2.1.3 Battery Connector

Batteries are connected via a removable pluggable, CN8. The HPSC104-SER accepts DC battery voltages in the range 6.5V to 35VDC through the Battery Power Connector.

- CN8-1: Common
- CN8-2: Battery Positive
- CN8-3: Battery Positive
- CN8-4: Common
- CN8-5: TH, thermistor/safety input
- CN8-6: SDA, I2C/SMBus data input/output signal
- CN8-7: SCL, I2C/SMBus clock input/output signal
- CN8-8: Battery Enable output

2.1.4 Aux Battery Connector

Tri-M Engineering battery packs such as the BAT-NiMh-4500 can be directly plugged into the HPSC104-SER through connector CN3 and CN7. Connector CN3 is a two row by four pin header and CN7 is a two row by two pin header, with the BAT104 battery packs having mating female connectors.

- CN3-1: Battery Positive
- CN3-2: Common
- CN3-3: Battery Positive
- CN3-4: Common
- CN3-5: SDA, I2C/SMBus data input/output signal
- CN3-6: SCL, I2C/SMBus clock input/output signal
- CN3-7: +5V for digital temperature sensor and battery enable
- CN3-8: BE, Battery Enable output

- CN7-1: Battery Positive
- CN7-2: Common
- CN7-3: Battery Positive
- CN7-4: Common

2.1.5 RS232 Serial Port Interface

The HPSC104-SER provides an RS232 serial port for remote control, monitoring and datalogging. The serial port connector is a standard DB9 connector, CN4.

- CN4-1: BL, Battery Low signal output (TTL level)
- CN4-2: TX-Out, RS232 output signal
- CN4-3: RX-IN, RS232 input signal
- CN4-4: SD-232, Shut Down signal input, RS232 signal levels
- CN4-5: Common
- CN4-6: Not used
- CN4-7: Not used
- CN4-8: Power fail indication
- CN4-9: Reserved

2.1.6 Control I/O Connector

The HPSC104-SER provides the following digital control signals:

- CN6-1: Common.
- CN6-2: PF, Power Fail signal output (TTL level per below).
- CN6-3: BL, Battery Low signal output (TTL level per below).
- CN6-4: IGN, Maintained contact input. Programmable polarity. 6-40VDC input range.
- CN6-5: SD, Momentary contact input. 6-40VDC input range.

Note: All outputs are active low.

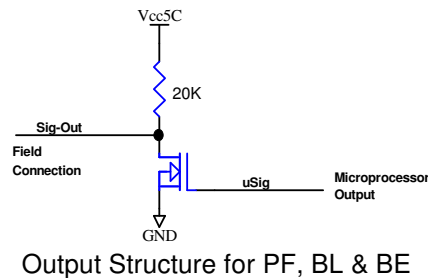

2.2 Jumper Selection

This section describes the function of each jumper, and the location of it.

2.2.1 Interrupt Service Request Jumpers

Jumper CN9 sets the interrupt service request to either IRQ5 or IRQ7.

- Pin 1 to 2, IRQ5
- Pin 2 to 3, IRQ7

2.2.2 PC/104 Memory Mapped Address Jumper

Jumper JP2 sets the PC/104 I/O Memory Mapped Address Jumper.

- Pin 1 to 3, Address 0x300 (300 hex)
- Pin 2 to 4, Address 0x310 (310 hex)
- Pin 5 to 3, Address 0x320 (320 hex)
- Pin 6 to 4, Address 0x360 (360 hex)