

# TBP4xxx

## USER GUIDE

Backup Power Module for HESC & HPSC Supplies

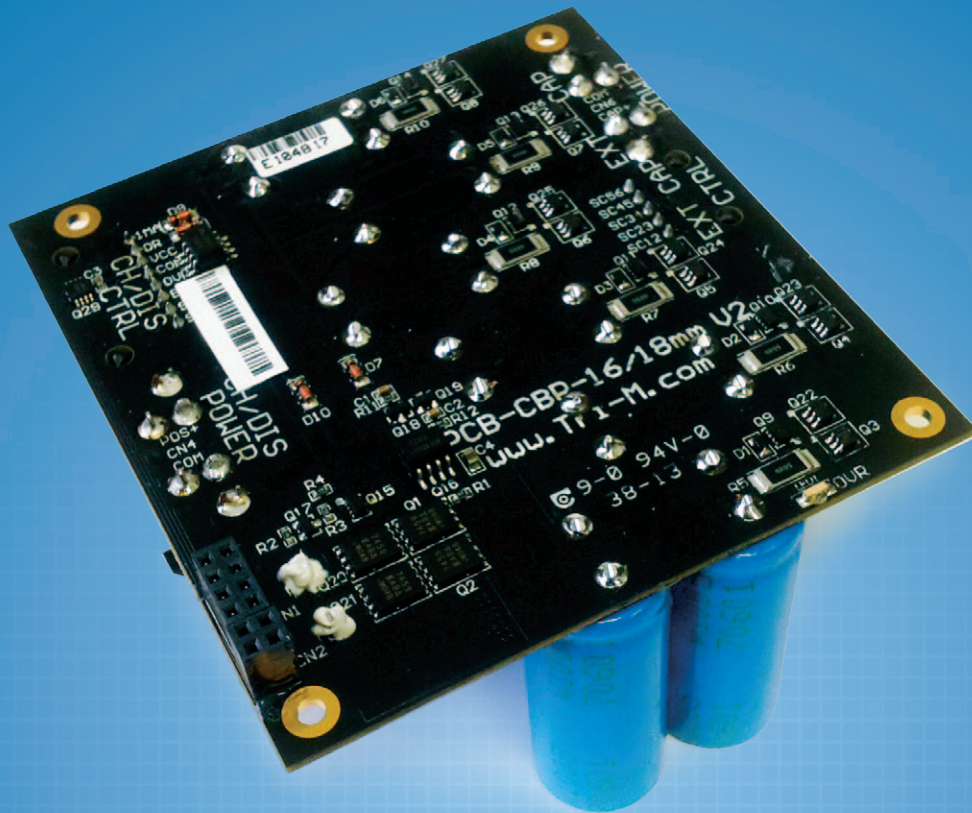

**Tri-M Technologies Inc.**

208 – 31510 Gill Avenue, Mission, BC, Canada V4S 0A1

Toll Free 800.665.5600 (North America)

Direct 604.814.5069 • info@tri-m.com

[www.tri-m.com](http://www.tri-m.com)

Rev 08/11

# Table of Contents

<b>Important Notes</b> .....	<b>2</b>	<b>CH4, Optional CH/DIS POWER Connector</b> . . .	<b>12</b>
About Tri-M Technologies Inc.		TBP41K0 & TBP42K0	
Technical Support		TBP4K50 & TBP44K0	
Tri-M Technologies Inc. (Limited Warranty)		<b>CN5, Optional EXT CAP CTRL Connector</b> .....	<b>13</b>
Disclaimer		<b>CN6, Optional EXT CAP Connector</b> .....	<b>13</b>
<b>Overview</b> .....	<b>4</b>	<b>Assembling the TBP4xxx to a Tri-M</b>	
<b>Key Features</b> .....	<b>4</b>	<b>HESC or HPSC Power Supply</b> .....	<b>14</b>
<b>Advantages</b> .....	<b>4</b>	Connection to an Remote Power Charger	
<b>TBP4xxx Specifications</b> .....	<b>5</b>	Connection to an External Ultra Capacitor Bank	
Backup energy		(TBP41K0, TBP42K0)	
Maximum voltage		<b>TBP4xxx Operation</b> .....	<b>15</b>
Temperature range		Capacitor Voltage Monitoring	
Size		Block Schematic	
Height		<b>Digital Temperature Sensor</b> .....	<b>16</b>
Recommended maximum load wattage		<b>Fuse Replacement</b> .....	<b>17</b>
Weight		<b>Determining Power Hold-Up Time</b> .....	<b>18</b>
Holdup times			
<b>TBP4K50 &amp; TBP44K0 Dimensions</b> .....	<b>6</b>		
<b>TBP4K50 &amp; TBP44K0 Connector Layout</b> .....	<b>7</b>		
<b>TBP41K0 &amp; TBP42K0 Dimensions</b> .....	<b>8</b>		
<b>TBP41K0 &amp; TBP42K0 Connector Layout</b> .....	<b>9</b>		
<b>Connector Specifications</b>			
<b>CN1, HESC &amp; HPSC Connector</b> .....	<b>10</b>		
<b>CN2, HPSC Connector</b> .....	<b>10</b>		
<b>CN3, Optional CH/DIS CTRL Connector</b> .....	<b>11</b>		

## Important Notes

This manual is intended for integrators of embedded system applications. It contains detailed information on hardware and software requirements for inter-connectivity to other embedded devices. Please carefully read this manual before you begin installing this product.

### About Tri-M Technologies Inc.

Tri-M Technologies Inc. engineers innovative power and computing solutions for embedded applications. Tri-M solutions are the premiere choice for off-highway vehicles, industrial controls, robotics, military equipment, aerospace technologies, and advanced security products. We offer a wide range of DC-to-DC converters, CPU boards, hardened enclosures, I/O modules, wireless communication devices, and custom built systems to operate in ruggedized environments. With over 28 years in providing world-class products and services, Tri-M is your Rugged Power Solutions provider for Hostile Environments.

### Technical Support

**Tri-M is pleased to provide technical support and services by phone, and email:**

- For Technical Manuals please visit the specific product page at [www.tri-m.com](http://www.tri-m.com)
- For technical support contact your Tri-M sales representative

### Tri-M Technologies Inc. (Limited Warranty)

*Unless otherwise agreed to in writing, Tri-M Technologies Inc. (Tri-M) warrants to the original purchaser that its products will be free from defects in material and workmanship for a period of (1) one year from the date of shipment. Tri-M's obligation under this warranty is limited to replacement or repair, at its option and its designated site, any such product within the warranty period that is returned to Tri-M in Tri-M approved packaging with a Tri-M-assigned RMA (Return Material Authorization) number referenced on the shipping document.*

*All warranties are void if there is evidence of misuse, tampering, or attempted repair of parts. Any returns must be accompanied by a return material authorization (RMA) number issued by Tri-M. Purchaser shall prepay transportation to Tri-M's designated site. If returned products are repaired or replaced under the terms of this warranty, Tri-M shall pay return transportation charges.*

*In no case will Tri-M be held liable for consequential damages arising out of its obligations under this warranty or the failure or incorrect use of any of its products. This warranty is in lieu of all warranties, either express or implied, including, without limitation, any implied warranty of merchantability or fitness for any particular purpose, and of any other obligation on the part of Tri-M.*

### Disclaimer

*No part of this document may be reproduced, transmitted, transcribed, stored in a retrieval system, or translated into any language or computer language, in any form or by any means, electronic, mechanical, magnetic, optical, chemical, manual, or otherwise, without the express written permission of Tri-M Technologies Inc.*

*Tri-M Technologies Inc. makes no representations or warranties with respect to the contents of this manual, and specifically disclaims any implied warranties of merchantability or fitness for any particular purpose. Tri-M Technologies Inc. shall under no circumstances be liable for incidental or consequential damages or related expenses resulting from the use of this product, even if it has been notified of the possibility of such damages. Tri-M Technologies Inc. reserves the right to revise this publication from time to time without obligation to notify any person of such revisions.*

COPYRIGHT © 2011 TRI-M TECHNOLOGIES INC.

## Overview

Tri-M's TBP4xxx series provides a complete UPS system in a PC/104 footprint when connected with Tri-M's HESC/HPSC power supplies. This innovative solution provides clean, robust, cost-effective, and uninterruptible power for hostile applications. The TBP4xxx module is the perfect solution for systems requiring a graceful shutdown and backup power after loss of main power. The TBP4xxx modules include six (or twelve ultracapacitors) wired in series (or series/parallel if twelve ultra capacitors) for a 13V maximum voltage capability. The TBP4xxx also features a digital temperature sensor that monitors the TBP4xxx temperature.

## Key Features

- Fully charged in less than a minute
- 500,000 charge cycles
- Deep discharge immune
- Extreme temperature operation
- High altitude capable (info available on request)
- Designed for high vibration and shock environments
- PC/104 size footprint
- Cable free mating with HESC & HPSC

## Advantages

- Designed to MIL Standards
- Prevents loss of data or corruption due to reliable system backup power
- Reduced downtime due to maintenance-free operation
- High Density PC/104 footprint
- Improved reliability due to cable free integration of HESC & HPSC

# TBP4xxx Specifications

Specification Detail	Units	Capacitive Backup Power Module			
		TBP4K50	TBP41K0	TBP42K0	TBP44K0
Backup energy (See Note 1)	joules	500	1000	2000	4000
Maximum voltage (See Note 2)	volts	13			
Temperature range	°C	-40 to 85			
	°F	-40 to 185			
Size (length and width)	inch	3.55 x 3.775			
	mm	90 x 96			
Height in addition to the standard 0.662” PC/104 card on the PC/104 stack.	inch	0	1.57	2.36	2.36
	mm	0	40	60	60
Recommended maximum load wattage	watts	40	40	80	80
Weight	ounces	4.2	6.7	11.6	17.3
	grams	120	190	330	490
Holdup time for 5 watt load	seconds	100	200	400	800
Holdup time for 10 watt load	seconds	50	100	200	400
Holdup time for 25 watt load	seconds	20	40	80	160
Holdup time for 50 watt load	seconds	not recommended		40	80

Note 1: The module backup energy is based on a cutoff of 7V.

Note 2: A minimum input of 14V for HESC & HPSC is required to fully charge the TBP4xxx backup power modules.

# TBP4K50 & TBP44K0 Dimensions

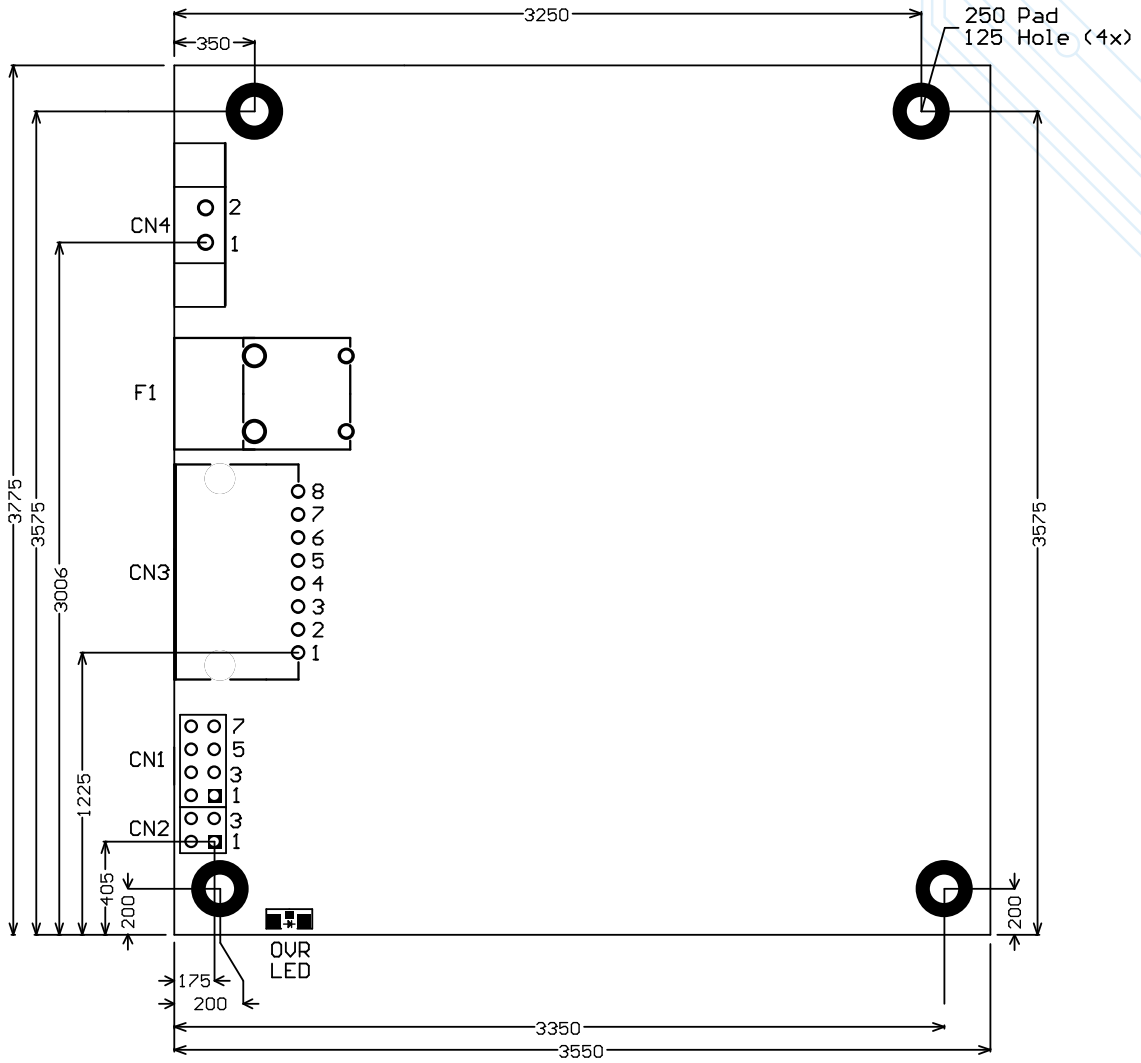

Dimensions are in mils. 1000 mils = 1 inch  
 The four mounting holes are per the PC/104 specification.

# TBP4K50 & TBP44K0 Connector Layout

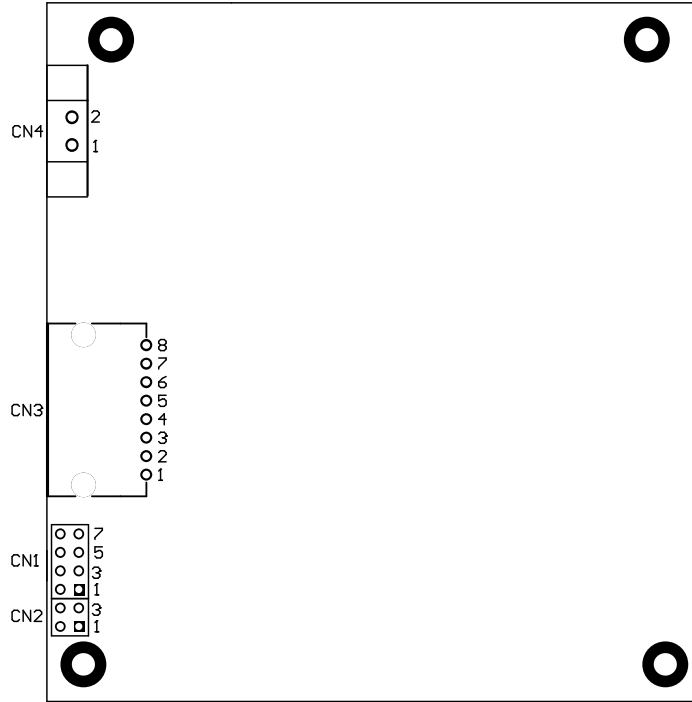

## TBP4K50, TBP44K0

Label	Build	Description	Manufacturer	Manufacturer Part Number	
				PCB	Plug/Fuse
CN1	Installed	Plugs to bottom of an HESC/HPSC power supply. 4x2 Header, 0.1" pin spacing.	Samtec	SSW-104-01-T-D	On the HESC/HPSC
CN2	Installed	Plugs to bottom of HPSC power supply. 2X2 Header, 0.1" pin spacing.	Samtec	SSW102-01-T-D	On the HPSC
CN3	Optional	Charge and discharge control signals. Eight position locking.	Molex	70555-0042	50-57-9408
		Female crimps 22-24 AWG			16-02-0102
CN4	Optional	Charge and discharge power control. Two position connector.	Phoenix	1827868	1827703
F1	Installed	Fuse 15A/32V MINI blade fast-acting.	Littelfuse Inc	3549	0297015.WXNV

# TBP41K0 & TBP42K0 Dimensions

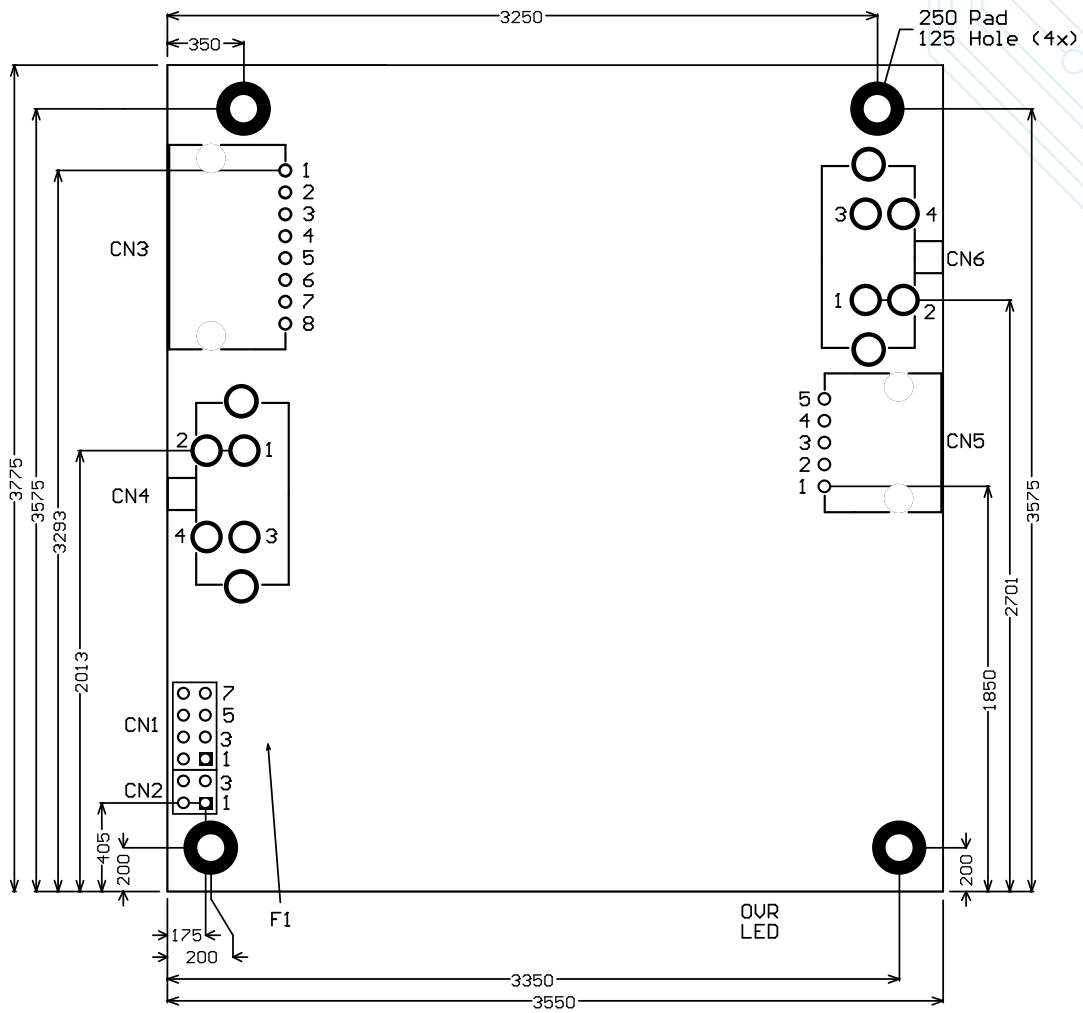

Dimensions are in mils. 1000 mils = 1 inch  
 The four mounting holes are per the PC/104 specification.  
 NOTE: CN3, CN4, CN5, CN6 and F1 are mounted on bottom side of PCB



# TBP41K0 & TBP42K0 Connector Layout

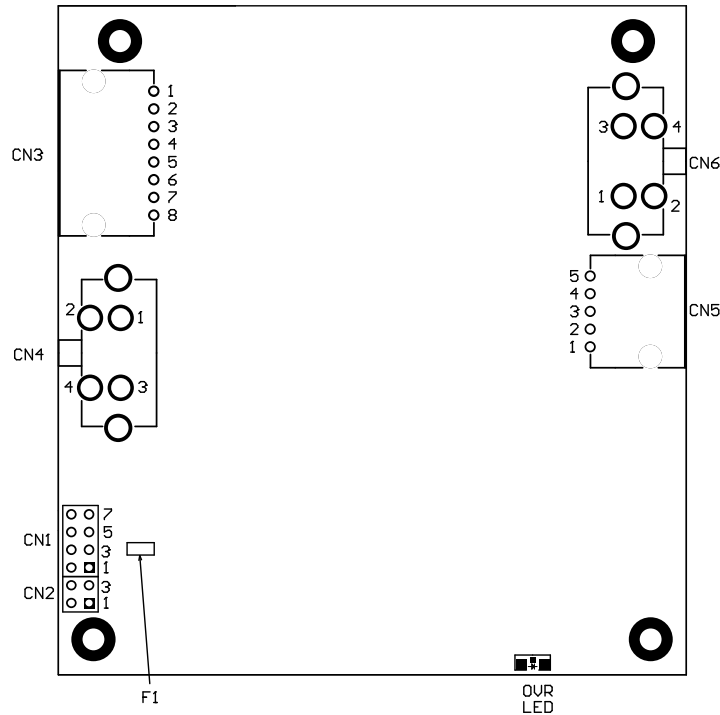

## TBP41K0, TBP42K0

Label	Build	Description	Manufacturer	Manufacturer Part Number	
				PCB	Plug/Fuse
CN1	Installed	Plugs to bottom of an HESC/HPSC power supply. 4x2 Header, 0.1" pin spacing.	Samtec	SSW-104-01-T-D	On the HESC/HPSC
CN2	Installed	Plugs to bottom of HPSC power supply. 2X2 Header, 0.1" pin spacing.	Samtec	SSW102-01-T-D	On the HPSC
CN3	Optional	Charge and discharge control signals. Eight position locking.	Molex	70555-0042	50-57-9408
		Female crimps 22-24 AWG			16-02-0102
CN4	Optional	Charge and discharge power control. Two position connector.	Molex	42819-2212	42816-0212
		Female crimps 10-12AWG			42815-0011
CN5	Optional	Ultra capacitor node voltages. Five position locking.	Molex	70555-0042	50-57-9405
		Female crimps 22-24 AWG			16-02-0102
CN6	Optional	Ultra capacitor rail voltages. Two position connector.	Molex	42819-2212	42816-0212
		Female crimps 10-12AWG			42815-0011
F1	Installed	Fuse 15A/32V MINI blade fast-acting.	Littelfuse Inc		0297015.WXNV

# Connector Specifications

The following sections describe the electrical and mechanical connector specifications.

## CN1, HESC & HPSC Connector

CN1 is a standard 4 x 2 header designed to connect directly to Tri-M's HESC/HPSC power supplies.

Pin #	Signal	Description	Range
1 & 3	CAP+	Positive connection for charge & discharge	0 to 13VDC
2 & 4	Com	Electrical common	0VDC
5	SDA	I <sup>2</sup> C Bidirectional Data Signal to/from HESC/HPSC or remote charger	Open collector signal pulled to Vcc by HESC/HPSC or remote charger
6	SCL	I <sup>2</sup> C Clock from HESC/HPSC or remote charger	Open collector signal pulled to Vcc by HESC/HPSC or remote charger
7	VccCtrl	Control power supplied by HESC/HPSC or remote charger	5VDC
8	GEN	Low active enable signal	0V = activate, Vcc = de-activate

## CN2, HPSC Connector

CN2 (2 x 2 header) connects to Tri-M's HPSC High Current Connector.

Pin #	Signal	Description	Range
1 & 3	CAP+	Positive connection for charge & discharge	0 to 13VDC
2 & 4	Com	Electrical common	0VDC

## CN3, Optional CH/DIS CTRL Connector

CN3 provides the control signals for remote connection.

Pin #	Signal	Description	Range
1	1MA	1mA current limited supply directly from positive of capacitors	1mA via current limiting diode.
2	OREN	Enables the DIMs (Discharge Isolation Mosfets) thus turning on the TBP4xxx. If an HESC/HPSC is the charger for the TBP4xxx then use of this signal should be by a momentary "contact" and not a maintained contact such as an ignition switch so that the HESC/HPSC can de-activate the TBP4xxx when not required.	1mA current limited. A dry contact between the 1mA signal and OREN can be used.
3	VccCtrl	Control power supplied by HESC/HPSC or remote charger	5VDC
4	Com	Electrical common	0VDC
5	OVR	Opto-isolated open collector status of any capacitor detected in an overvoltage condition	Hi-impedance = normal operation. 0V = overvoltage condition exists on one of more capacitors.
6	GEN	Low active enable signal	0V = activate, VccCtrl = de-activate
7	SDA	I <sup>2</sup> C Bidirectional Data Signal to/from HESC/HPSC or remote charger	Open collector signal pulled to VccCtrl by HESC/HPSC or remote charger.
8	SCL	I <sup>2</sup> C Clock from HESC/HPSC or remote charger	Open collector signal pulled to VccCtrl by HESC/HPSC or remote charger.

## CH4, Optional CH/DIS POWER Connector

CN4 provides connection for a remote charger arrangement

### TBP41K0 & TBP42K0

Pin #	Signal	Description	Range
1 & 3	CAP+	Positive connection for charge & discharge	0 to 13VDC
2 & 4	Com	Electrical common	0VDC

### TBP4K50 & TBP44K0

Pin #	Signal	Description	Range
1	CAP+	Positive connection for charge & discharge	0 to 13VDC
2	Com	Electrical common	0VDC

## CN5, Optional EXT CAP POWER Connector

CN5 provides the inter-capacitor node for “capacitor balancing”.

Pin #	Signal	Description	Range
1,2	VccSC1	Positive connection of ultracapacitor bank	0 to 13VDC
3,4	Com	Electrical common	0VDC

## CN6, Optional EXT CAP Connector

CN6 provides the inter-capacitor node for “capacitor balancing”.

Pin #	Signal	Description	Maximum Node Voltage
1	VccSC12	Node between ultracapacitor 1 and 2	VccSC12, 11.6
2	VccSC23	Node between ultracapacitor 2 and 3	VccSC23, 9.3
3	VccSC34	Node between ultracapacitor 3 and 4	VccSC34, 6.9
4	VccSC45	Node between ultracapacitor 4 and 5	VccSC45, 4.6
8	VccSC56	Node between ultracapacitor 5 and 6	VccSC56, 2.3

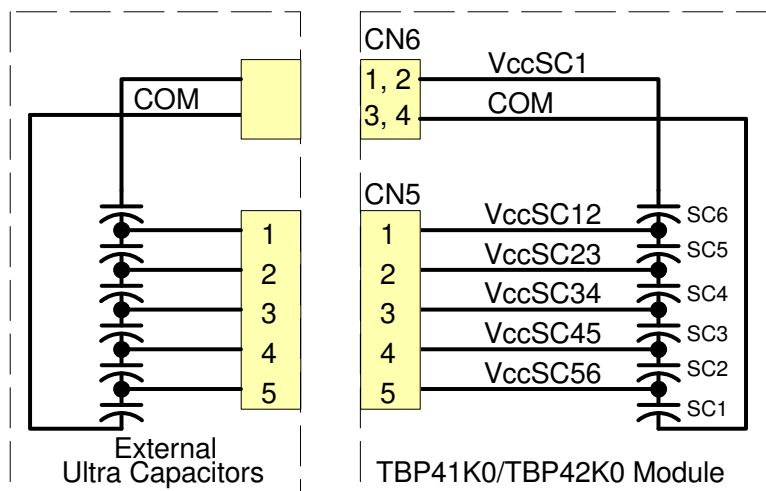

# Assembling the TBP4xxx to a Tri-M HESC or HPSC Power Supply

CN1 and CN2 plug directly to the bottom of Tri-M's HESC and HPSC power supply using 0.6 inch spacers between the HESC/HPSC and TBP4xxx. The 0.6 inch spacers available in Tri-M's hardware kit (MTG-BR-KIT).

## Note

When a TBP4K50 is stacked with an HESC104 or HPSC104-SER power supply the HESC104/HPSC104-SER must have a non-stackthrough PC/104 bus (-NS) or no PC/104 bus (-N) installed to prevent a physical component interference."

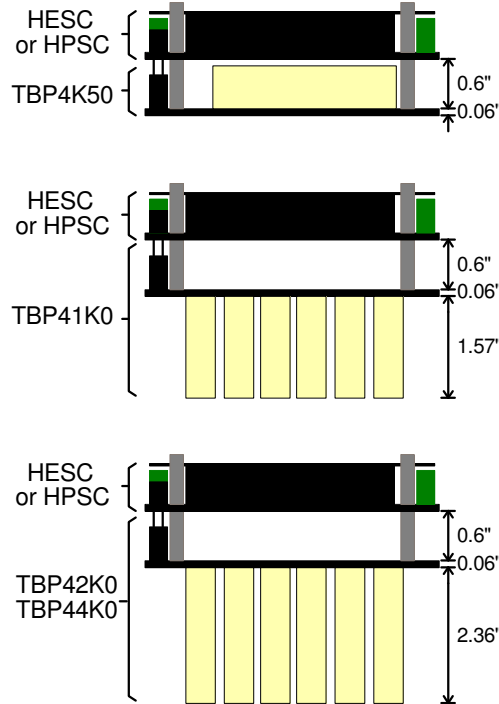

## Connection to an Remote Power Charger

The TBP4xxx may be located remotely from the HESC/HPSC or some other charger system and cabled together. Optional connectors CN3 and CN4 must be installed to provide access to the control and power rails of the TBP4xxx. CN3 and CN4 connector part numbers are listed in the Connector Layout table. Please contact Tri-M to arrange for factory installation of CN3 and CN4.

## Connection to an External Ultra Capacitor Bank (TBP41K0, TBP42K0)

An external capacitor bank can be added in parallel to the ultra capacitors on the TBP4xxx to increase backup energy. Optional connectors CN5 & CN6 must be installed. CN5 provides the inter-capacitor node for "capacitor balancing" and CN6 provides the connection to the positive and common power rails of external ultra capacitor bank. CN5 and CN6 connector part numbers are listed in the Connector Layout table. Please contact Tri-M to arrange for factory installation of CN5 and CN6.

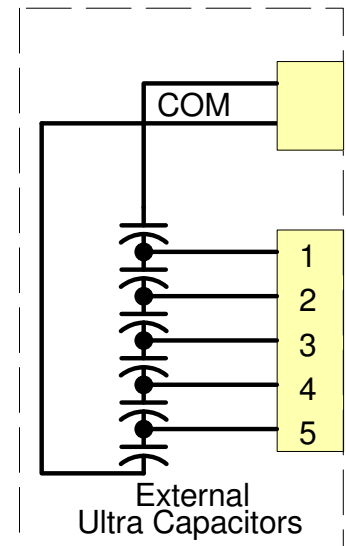

The external ultra capacitor bank must be rated for at least 13.0 volts.

# TBP4xxx Operation

## Capacitor Voltage Monitoring

Due to manufacturing tolerances each ultra capacitor has small differences in capacitance and leakage current. These differences result in different charge rates for each ultra capacitor and unless some “balancing” method is employed an overvoltage will eventually on one of the ultra capacitors. To prevent an overvoltage from each ultra capacitor (TBP44K0) or pair of ultra capacitors (TBP4K50, TBP41K0 & TBP42K0) has two Voltage Monitoring Controllers (VMCs). A 2.2V VMC shunts (bypasses) current around its ultra capacitor through a 4.99 ohm resistor should the voltage rise above its setpoint. If the voltage across an ultra capacitor continues to rise and a second VMC with a 2.3V threshold will generates an overvoltage signal (OV-DETECT) activating the Charge Isolation Mosfets (CIMs) preventing additional charging of the TBP4xxx. The TBP4xxx will still provide backup power even when the CIMs are activated. To prevent repeated overcharging of the ultra capacitors, the CIMs can only be reset to normal operation by the removal of the charging voltage.

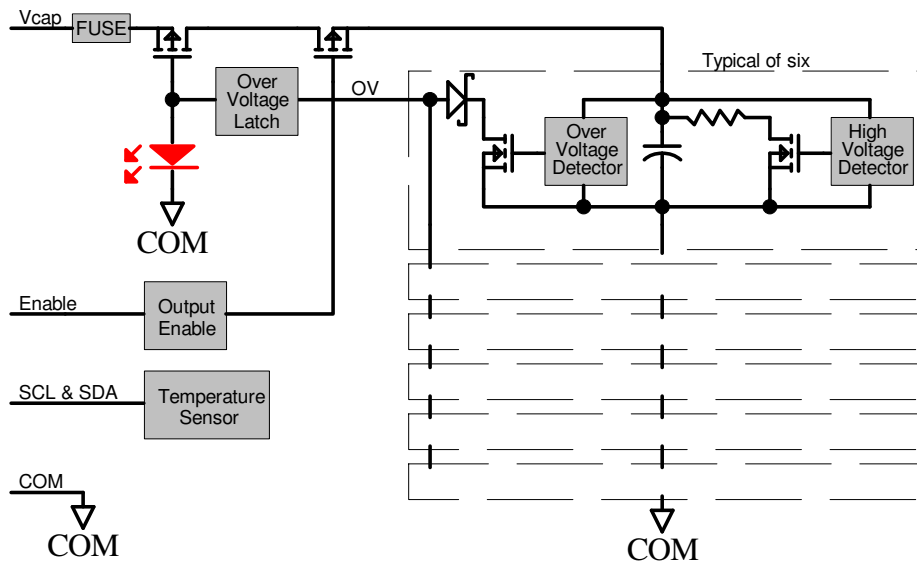

The OVR LED indicates when one of the ultra capacitors has activated the OV-DETECT signal. The OV-DETECT signal is available for external monitoring by populating the optional CN3 (CH/DIS CTRL) connector. The external OV-DETECT is an opto-isolated open collector signal on pin 5 of CN3.

## Digital Temperature Sensor

The TBP4xxx includes an I2C temperature sensor with its address set to 0x4F (79 decimal). The I2C temperature readings are available when VccCtrl power is applied. When the TBP4xxx is mated with an HESC/HPSC the VccCtrl power is applied when the HESC/HPSC has power either from its main input or from the TBP4xxx. For example, if the TBP4xxx was enabled through OREN (available on the optional CN3 connector), backup power from the TBP4xxx would flow to the HESC/HPSC which would in return supply the VccCtrl to the TBP4xxx. The temperature sensor readings can be accessed over the I2C port on connector CN1 (or on the optional CN3 connector).

When using the SCU.exe utility to configure an HESC/HPSC power supply to read the TBP4xxx temperature sensor set the “I2C Temperature Sensor Address” to 79 (decimal) and enable the “Address R/W, Enable for Read, Disable For Write” check box (located in the “Temperature Sensor Control” settings).

### I2C Address Byte (0x4F)

Bit 7	Bit 6	Bit 5	Bit 4	Bit 3	Bit 2	Bit 1	Bit 0
1	0	0	1	1	1	1	R/W, R=1



## Fuse Replacement

If excessive current flow occurs the current protective fuse will activate. The automotive style MINI Blade 15A fuse (F1) allows for field replacement. The factory installation includes a little RTV on the fuse blades for shock and vibration purposes.

Tri-M Part#	Description	Mechanical Specifications
FUSE-MINI-15A	Fuse 15A/32V MINI Blade Fast-act	Plugs into F1, Littlefuse Inc, 0297015.WXNV

### Waking a TBP4xxx from “Hibernate Mode” without Main Power

A TBP4xxx can be woken from Hibernate Mode (backup power disabled) without main power by connecting a momentary dry contact between the 1MA signal (pin 1 of optional CN3) and OREN (pin 2 of optional CN3). When the mated HESC/HPSC is configured to start on “battery” it will recognize the TBP4xx awakening from Hibernate as a start up request.

## Determining Power Hold-Up Time

The hold-up time can be estimated from the TBP4xxx Specification table on page 5 of this user guide.