

V5SC Manual

Vehicle 5V Power Supply & *Smart Charging* DC to DC Converter

Manufactured by
TRI-M ENGINEERING
Engineered Solutions for Embedded Applications

Technical Manual

P/N: V5SC-MAN
Revision: 8 March 2006

TRI-M ENGINEERING
1407 Kebet Way, Unit 100
Port Coquitlam, BC V3C 6L3
Canada
<http://www.Tri-M.com>
Tel 604.945.9565
North America 800.665.5600
Fax 604.945.9566

Table of Contents

CHAPTER 1 - INTRODUCTION	4
1.1 GENERAL DESCRIPTION.....	4
1.2 FEATURES	5
1.3 SPECIFICATIONS.....	6
CHAPTER 2 - CONFIGURATION AND INSTALLATION	7
2.4 INTRODUCTION.....	7
2.4.1 <i>Main Input Power Connector</i>	7
2.4.2 <i>Output Power Connector</i>	8
2.4.3 <i>External Battery Connector</i>	8
2.4.4 <i>Aux Battery Connector</i>	8
2.4.5 <i>RS232 Serial Port Interface</i>	9
2.5 JUMPER SELECTION.....	9
CHAPTER 3 - USING HESC POWER MANAGEMENT FEATURES.	10
APPENDIX 1 - EXTERNAL BATTERY DESIGN.....	12
4.1 BATTERY ISOLATION	12
4.2 DIGITAL SENSOR INTERFACE	12

PREFACE

This manual is for integrators of applications of embedded systems. It contains information on hardware requirements and interconnection to other embedded electronics.

DISCLAIMER

Tri-M Engineering makes no representations or warranties with respect to the contents of this manual, and specifically disclaims any implied warranties of merchantability or fitness for any particular purpose. Tri-M Engineering shall under no circumstances be liable for incidental or consequential damages or related expenses resulting from the use of this product, even if it has been notified of the possibility of such damages. Tri-M Engineering reserves the right to revise this publication from time to time without obligation to notify any person of such revisions. If errors are found, please contact Tri-M Engineering at the address listed on the title page of this document.

COPYRIGHT © 2000-03-22 TRI-M ENGINEERING

No part of this document may be reproduced, transmitted, transcribed, stored in a retrieval system, or translated into any language or computer language, in any form or by any means, electronic, mechanical, magnetic, optical, chemical, manual, or otherwise, without the express written permission of Tri-M Engineering.

CHAPTER 1 - INTRODUCTION

1.1 GENERAL DESCRIPTION

The V5SC is a high performance DC-to-DC 35 watt converter that supplies +5V. The V5SC also includes a flash based microcontroller that supplies advanced power management, smart battery charger and an RS232 serial port. The V5SC is designed for low noise embedded computer systems, has a wide input range of 6-40V(>6:1) and is ideal for battery or unregulated input applications. The V5SC is specifically designed for vehicular applications and has heavy-duty transient suppressors (6000W) that clamp the input voltage to safe levels, while maintaining normal power supply operation.

The V5SC is a state-of-the-art mosfet based design that provides outstanding line and load regulation with efficiencies up to 95 percent. Organic Semiconductor Capacitors provide filtering that reduces ripple noises below 20mV. The low noise design makes the V5SC ideal for use aboard aircraft or military applications or wherever EMI or RFI must be minimized. A constant off-time current-mode architecture regulator provides excellent line and load transient response for the +5VDC output.

The V5SC has a built-in 750mA-Hr 8.4V NiMh battery that is re-charged by the V5SC battery charger. The V5SC also supports external battery packs such as the BAT104-NiMh, or a non-PC/104 pack that is wired to the Battery Connector CN1. The V5SC utilizes a multi-stage charging for both the built-in batteries and the external batteries. The V5SC provides up to four stages of battery charging and can charge Lead-Acid, NiCd, and NiMh batteries and is also SMBus level 3 compatible. Charge currents are up to 1.5A, and battery charging voltages from 9.5 to 19.5V.

The V5SC has advanced power management functions that allows timed on/off control of the V5SC, notification of changes to main power and changes in the battery status. For example, the V5SC can be programmed to power off the outputs in 60 seconds, and then turn on again 12 hours later.

The V5SC size is 3.55 x 3.775 inches, which is the same size as the PC/104 standard, and has the same mounting holes pattern as the PC/104 standard. However, the V5SC does not supply the PC/104 bus connectors. (For a PC/104 fully compliant power supply, please see the Tri-M Engineering HESC104.) All generated voltages are provided to screw terminals. The RS232 serial port is provided on a 2x5 row pin header.

The V5SC can be configured to meet almost any power supply and battery charging need for embedded applications, whether that be a simple +5V application, or providing power for back lighted LCD panels, or a full UPS (un-interruptible power supply configuration).

1.2 FEATURES

- DC to DC converter for embedded applications.
- "Load Dump" transient suppression on input power supply.
- Operates from 6VDC to 40VDC input.
- PC/104 size and mounting holes.
- 35 watt power supply outputs.
- 5V, and battery charger outputs.
- Temperature range 0 to 70C (Limited by the built-in batteries)
- Monitors up to eight temperatures (seven external) using I2C digital temperature sensors.
- RS232 serial port for setup, monitoring and control.
- Opto-coupled inputs for ignition, and system "shut-down" pushbutton.

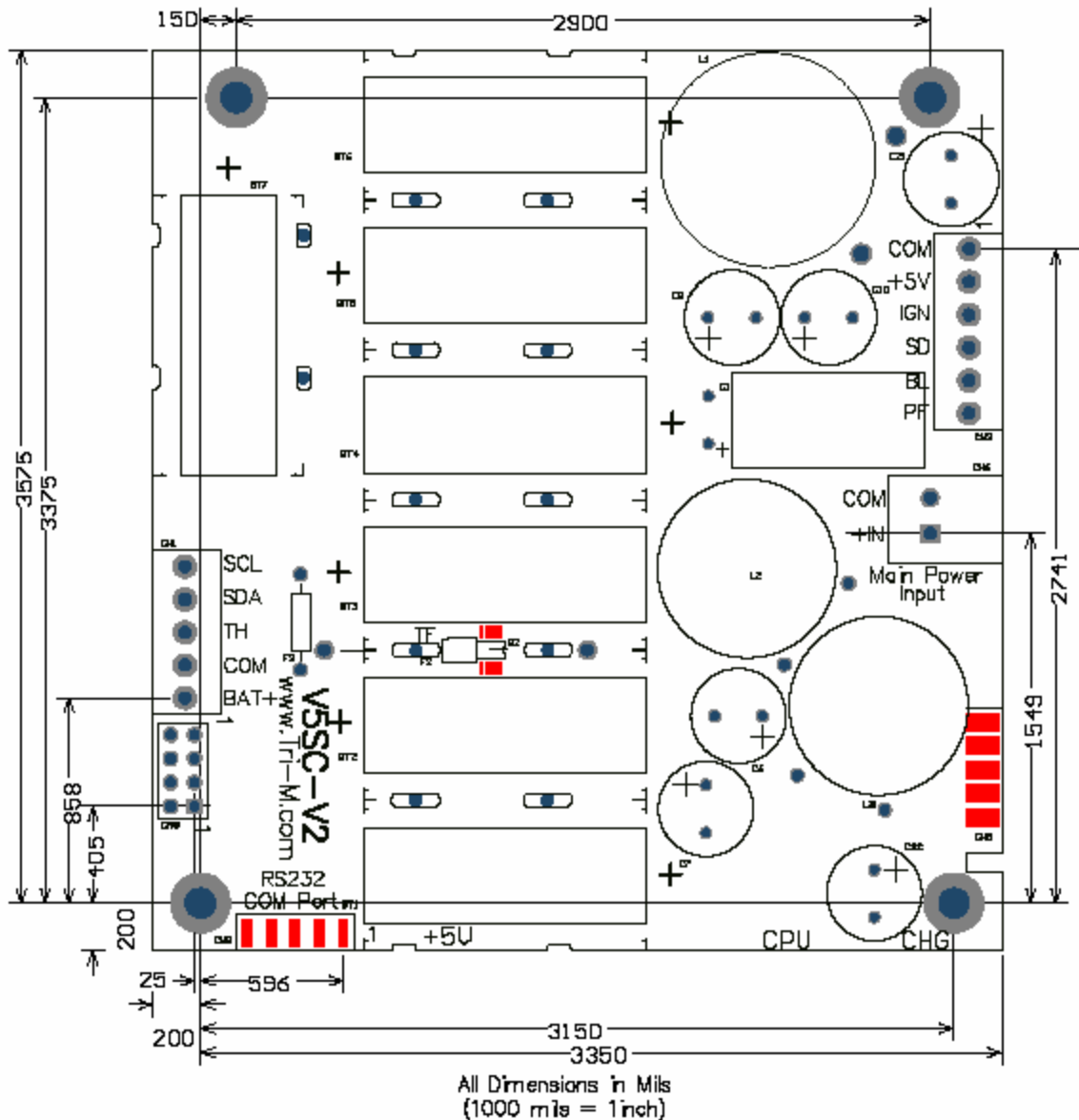

1.3 SPECIFICATIONS

Power Supply Specifications	
Model	V5SC
5V output	7 A
Input Voltage Range	6 to 40V
Load Regulation	<60mV
Line Regulation	+/-40mV
Output Temperature Drift	<40mV
Switching Frequency	75 to 100khz
Output Ripple	<20mV
Conducted Susceptibility	>57db
Efficiency	Up to 95%
Temperature Range	0 to 70C (limited by NiMh batteries)
Internal Battery Pack	7 cells NiMh, 750mA-hr
Size, PC/104 dimensions and mounting holes	3.55"W, x 3.75"L, x 0.6"H

CHAPTER 2 - CONFIGURATION AND INSTALLATION

2.4 Introduction

This chapter describes the configuration and installation of the V5SC power supply. In addition, section 2.2 provides a formula to calculate the available +5VDC. Figure 2-1 shows the V5SC connectors, jumpers and other options.

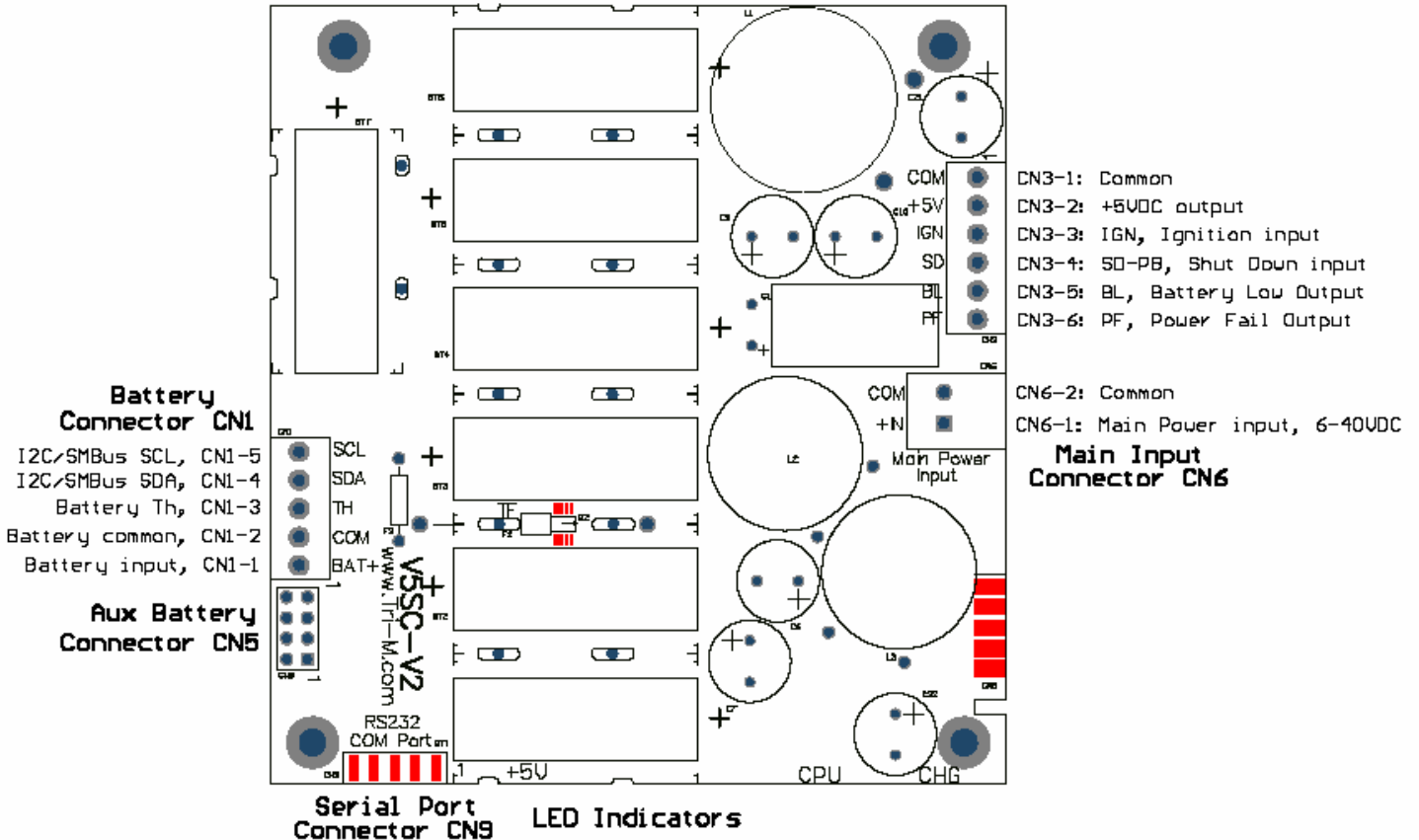

2.4.1 Main Input Power Connector

Input power is connected to the V5SC by a removable plug and socket connector CN6. The power supply accepts DC input voltages in the range of 6VDC to 40VDC.

Unregulated vehicle power is connected as follows:

- Terminal 1: "hot" polarity
- Terminal 2: Common (0VDC)

2.4.2 Output Power Connector

Output power is available for use via screw terminal connector CN3

- CN3-1: Position 1, Common
- CN3-2: Position 2, +5VDC output
- CN3-3: Position 3, IGN (Ignition input, ie maintained contact closure) 6-40V DC
- CN3-4: Position 4, SD-PB (Shut Down input, ie push button input) 6-40V DC
- CN3-5: Position 5, BL (Battery Low signal output) TTL logic level
- CN3-6: Position 6, PF (Power Fail signal output) TTL logic level

Note: All outputs are active low. The active state of the IGN signal is programmable by using SCU.exe utility.

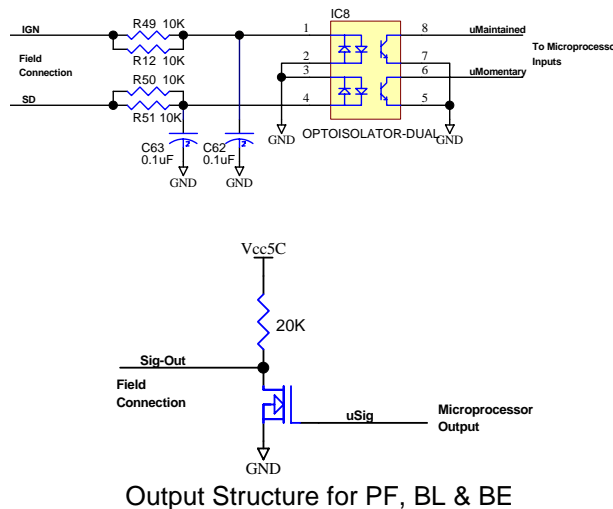

2.4.3 External Battery Connector

External Batteries are connected via the screw terminal connector, CN1. The V5SC accepts DC battery voltages in the range 6.5V to 35VDC through the Battery Power Connector (maximum charging voltage is limited to 19.5V)

- CN7-1: Battery Positive
- CN7-2: Common
- CN7-3: TH, thermistor/safety input
- CN7-4: SDA, I2C/SMBus data input/output signal
- CN7-5: SCL, I2C/SMBus clock input/output signal

2.4.4 Aux Battery Connector

Tri-M Engineering battery packs such as the BAT104-NiCd, BAT104-NiMh, BAT104-SLA25 and BAT104-SLA45 can be directly plugged into the V5SC through connector CN5. Connector CN5 is a two row by four-pin header, with the BAT104 battery packs having a mating female connector.

- CN5-1: Battery Positive
- CN5-2: Common
- CN5-3: Battery Positive
- CN5-4: Common
- CN5-5: SDA, I2C/SMBus data input/output signal
- CN5-6: SCL, I2C/SMBus clock input/output signal
- CN5-7: +5VC, +5V for digital temperature sensor and battery enable
- CN5-8: BE, Battery Enable output

2.4.5 RS232 Serial Port Interface

The V5SC provides an RS232 serial port for remote control, monitoring and datalogging. The serial port connector is a two row by five-pin header connector, CN9.

- CN9-1: BL, Battery Low signal output (TTL level)
- CN9-2: Not used
- CN9-3: TX-Out, RS232 output signal
- CN9-4: Not used
- CN9-5: RX-IN, RS232 input signal
- CN9-6: PF-232, Power Fail signal output, RS232 signal levels
- CN9-7: SD-232, Shut Down signal input, RS232 signal levels
- CN9-8: Not used
- CN9-9: Common
- CN9-10: Common

2.5 Jumper Selection

There are no option jumpers on the V5SC.

CHAPTER 3 - Using HESC Power Management Features.

Note: In order to use the advanced power management features, the V5SC must have the HESC-UPS Firmware loaded. Please refer to the HESC-UPS manual for details.

By monitoring and activating the following inputs and outputs, the V5SC power supply is capable of responding to changes in input supply and battery voltage to alert the host CPU of such conditions. To help accomplishing this task with ease, TRI-M provides a Windows based Smart Charger Utility (SCU.exe). This utility is also required when changing the charge profile for different batteries or future firmware update.

- CN3-3: IGN (Ignition input, ie maintained contact closure)
- CN3-4: SD-PB (Shut Down input, ie push button input)
- CN3-5: BL (Battery Low signal output)
- CN3-6: PF (Power Fail signal output)

IGN and SD response to 6-40V DC input as logic high. It can be triggered on either low or high level of input. The input polarity is set by changing one of the Charger flag. Figure 3-1 is a snap-shot of the SCU utility page which shows the charger flags. When the flag is unchecked, SD and IGN react to logic high input and vice-versa with flag checked.

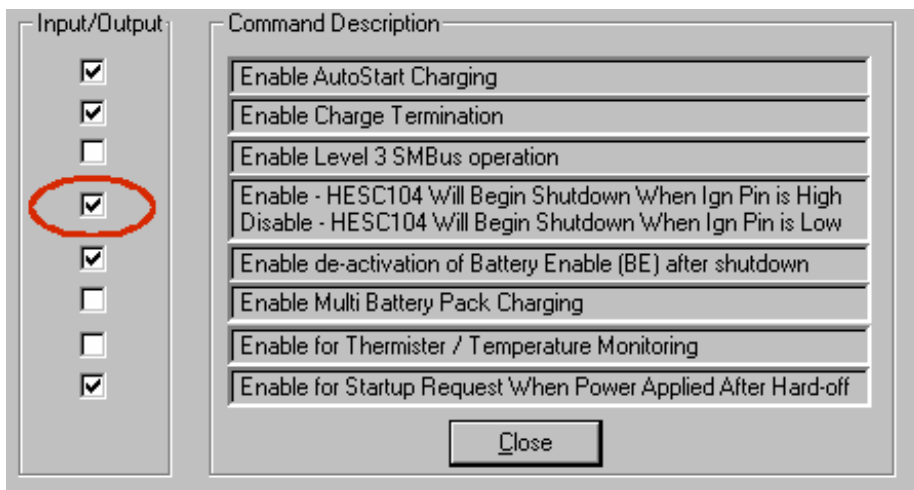

Figure 3-1

BL is driven low when the battery voltage is below the setpoint value of Minimum Battery Operating Voltage EEPROM variable. Figure 3-2 shows this variable under the OTHER EEPROM SETPOINTS page. Please note the unit of 9400 is in millivolts.

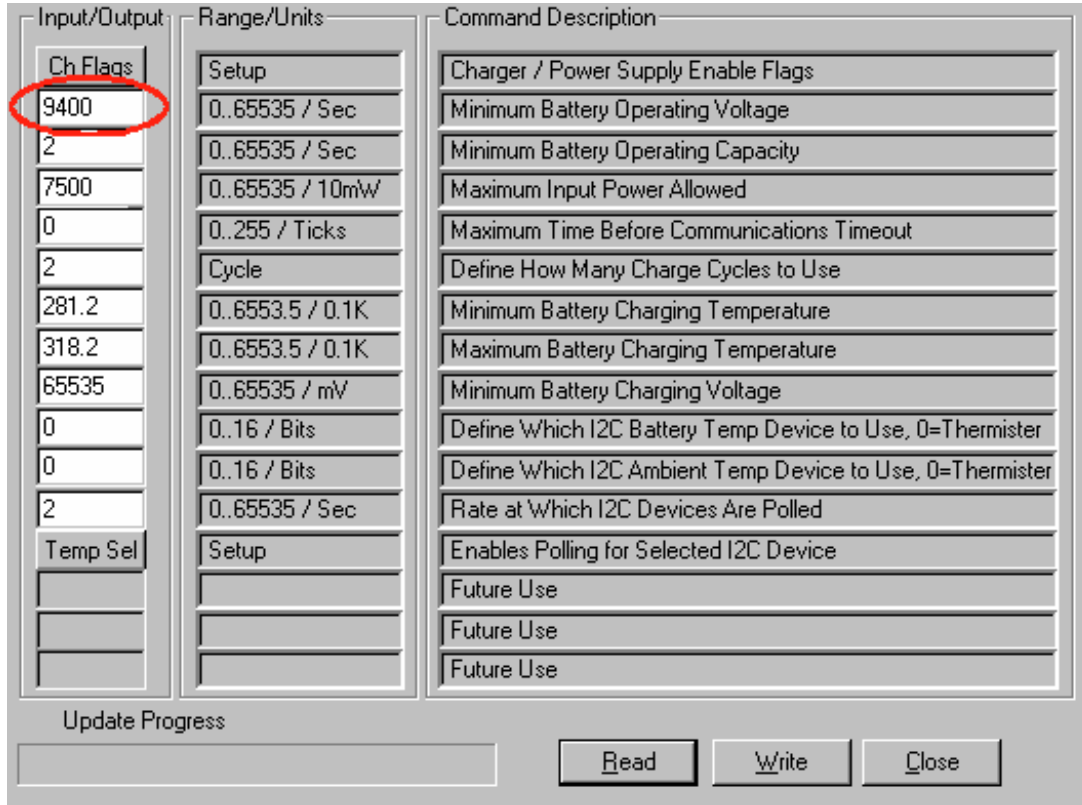

Figure 3-2

PF is driven active low after the main input power is removed and the “debounce” interval is completed or whenever there is a pending shutdown of the main outputs.

IGN, SD, BL and PF can be used to signal the host CPU to prepare for shutdown. It is critical that operating systems such as Linux and Windows are shutdown gracefully otherwise corruption of the OS and the file system may result.

When any of the four signals (BL, PF, SD, IGN) becomes active, the corresponding counter will begin counting down to zero. When the counter reaches zero, a shutdown command is issued to switch off the V5SC outputs immediately.

APPENDIX 1 - External Battery Design.

4.1 Battery Isolation

The V5SC allows for an external backup battery to be connected. For applications where long periods of power interruption may occur, a Mosfet isolation circuit should be used to prevent deep cycling the batteries. The Auxiliary Battery connector CN5 includes a Battery Enable (BE) signal to control the Mosfet isolation circuit. Below is a circuit complete with typical component values.

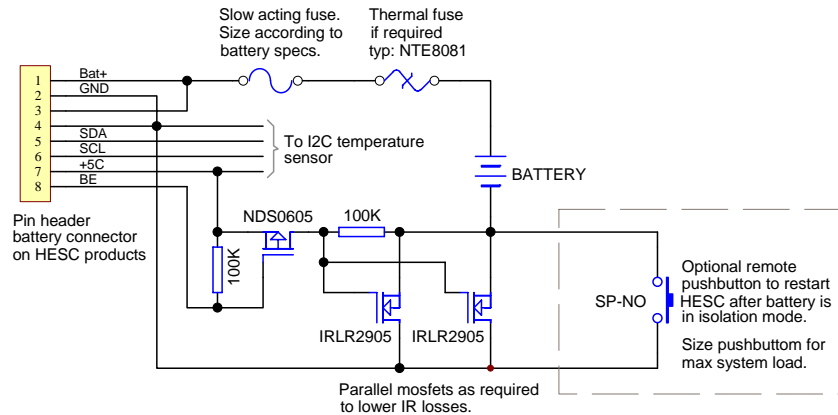

Figure 1: Battery Mosfet Isolation Circuit

4.2 Digital Sensor Interface

The V5SC has a built-in I²C digital sensor and supports connection of an additional seven more I²C digital sensors of Microchip (TCN75) and National (LM75CIM). These I²C are “two wire” devices and require connection of a bi-directional data line (SDA) and a bidirectional clock line (SCL). In addition, 5V power and Gnd are required. Both SDA and SCL along with 5V and Gnd are available through the eight-pin battery header connector (see Figure A1) on HESC products. SDA and SCL are also available on the five-position screw terminal block (see section 2.3.3) on the HESC104.

Note: The built-in I²C digital sensor on the V5SC has lines A0, A1, & A2 connected to Gnd.

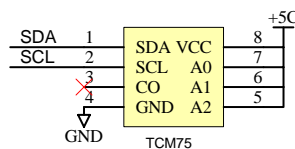

Figure 2: Digital Temperature Sensor