

VDX104 Manual

**PC/104(+) x86 CPU module,
with IDE, Four Serial ports, Ethernet,
USB 2.0, Parallel port and Compact Flash**

**For models:
VDX104+2E
VDX104+1E
VDX104-1E**

**Manufactured by:
TRI-M TECHNOLOGIES INC.**
Engineered Solutions for Embedded Applications

Technical Manual

P/N: VDX104-MAN
Revision: 18 NOVEMBER 2010

TRI-M TECHNOLOGIES INC.
1407 Kebet Way, Unit 100
Port Coquitlam, BC V3C 6L3
Canada
<http://www.Tri-M.com>
Tel 604.945.9565
North America 800.665.5600
Fax 604.945.9566

PREFACE

This manual is for integrators of applications of embedded systems. It contains information on hardware requirements and interconnection to other embedded electronics.

DISCLAIMER

Tri-M Technologies Inc. makes no representations or warranties with respect to the contents of this manual, and specifically disclaims any implied warranties of merchantability or fitness for any particular purpose. Tri-M Technologies Inc. shall under no circumstances be liable for incidental or consequential damages or related expenses resulting from the use of this product, even if it has been notified of the possibility of such damages. Tri-M Technologies Inc. reserves the right to revise this publication from time to time without obligation to notify any person of such revisions. If errors are found, please contact Tri-M Technologies Inc. at the address listed on the title page of this document.

COPYRIGHT © 2008-05-30 TRI-M TECHNOLOGIES INC.

No part of this document may be reproduced, transmitted, transcribed, stored in a retrieval system, or translated into any language or computer language, in any form or by any means, electronic, mechanical, magnetic, optical, chemical, manual, or otherwise, without the express written permission of Tri-M Technologies Inc..

CHAPTER 1: GENERAL DESCRIPTION..... 6

1.1 SPECIFICATIONS/FEATURES 6

 1.1.1 Vortex86DX 6

 1.1.2 Memory..... 6

 1.1.3 RS232 Interface 6

 1.1.4 Universal Serial Bus Interface 6

 1.1.5 Ethernet Interface..... 6

 1.1.6 Parallel Interface 7

 1.1.7 Keyboard/Mouse Interface 7

 1.1.8 Enhanced IDE Interface..... 7

 1.1.9 On board backup battery..... 7

 1.1.10 Expansion BUS - PC/104+ signals 7

 1.1.11 Flash Storage..... 7

 1.1.12 Jumperless configuration 7

 1.1.13 Software Compatibility..... 7

 1.1.14 Mechanical/Environmental..... 7

CHAPTER 2: INSTALLATION..... 8

2.1 LOCATING THE TOP CONNECTORS 8

2.2 LOCATING THE BOTTOM CONNECTORS 9

CHAPTER 3: JUMPERS 10

CHAPTER 4: CONNECTORS..... 11

4.1 COMPACT FLASH SOCKET (CN1) 12

4.2 IDE INTERFACE (CN2)..... 13

4.3 SERIAL PORTS RS232 (CN8, CN9, CN10 AND CN11)..... 14

4.4 PARALLEL PORT (CN12)..... 14

4.5 UNIVERSAL SERIAL BUS (CN13)..... 15

4.6 MICROSD SOCKET (CN14) VDX104+2E ONLY 15

4.7 USB DEVICE PORT (CN15) VDX104+2E ONLY 16

4.8 REDUNDANCY PORT AND I2C (CN16) 16

4.9 PS/2-SPI PORT (CN17) 17

4.10 JTAG PORT (CN18) 18

4.11 PC/104 BUS (CN19 AND CN21)..... 19

4.12 PC/104+ BUS (CN20) VDX104+1E & VDX104+2E ONLY 21

4.13 LAN INTERFACE 1 (CN22)..... 22

4.14 LAN INTERFACE 2 (CN23) VDX104+2E ONLY 22

4.15 INPUT POWER (CN24)..... 23

4.16 GPIO 0 PORT (CN26)..... 24

4.17 ON-BOARD USB 2.0 EXTENSION MODULE (CN32)..... 24

CHAPTER 5: GENERAL PURPOSE INPUT/OUTPUT 25

5.1 OVERVIEW 25

5.2 GPIO PORT 0 25

5.3 GPIO PORT 1 26

5.4 GPIO PORT 2 27

5.5 GPIO PORT 3 28

5.6 GPIO PORT 4 29



CHAPTER 6: WATCHDOG TIMER 30

6.1 OVERVIEW 30

6.2 WDT0 REGISTERS 30

6.3 WDT1 REGISTERS 32

CHAPTER 7: CMOS RAM..... 34

7.1 OVERVIEW 34

7.2 CMOS RAM MAPPING 34

CHAPTER 8: REDUNDANCY 35

8.1 OVERVIEW 35

8.2 BLOCK DIAGRAM 35

8.3 TRI-STATED DEVICES 36

8.4 SYSTEM INTERCOMMUNICATION 36

CHAPTER 9: ONBOARD SPI FLASH (VDX104+2E ONLY)..... 37

9.1 OVERVIEW 37

9.2 SPITool 37

CHAPTER 10: ONBOARD LED'S..... 38

10.1 OVERVIEW 38

10.2 LED1 38

10.3 LED2 (VDX104+2E ONLY) 38

10.4 LED3 38

10.5 LED4 (VDX104+2E ONLY) 38

CHAPTER 11: CONSOLE REDIRECTION 39

11.1 OVERVIEW 39

11.2 FORCE CONSOLE REDIRECTION ON 39

11.3 DEFAULT SETTINGS 39

CHAPTER 12: BIOS..... 40

12.1 MAIN MENU 40

12.2 ADVANCED SETTINGS..... 41

12.3 CPU CONFIGURATION 42

12.4 IDE CONTROLLER CONFIGURATION..... 43

12.5 IDE DEVICES CONFIGURATION 44

12.6 CONSOLE REDIRECTION CONFIGURATION 45

12.7 USB CONTROLLER CONFIGURATION..... 46

12.8 USB STORAGE DEVICES CONFIGURATION 47

12.9 PCI/PNP CONFIGURATION 48

12.10 BOOT MENU 50

12.11 BOOT OPTIONS 51

12.12 BOOT PRIORITY OVERALL..... 52

12.13 BOOT PRIORITY FOR HARD-DRIVE..... 53

12.14 BOOT PRIORITY FOR REMOVABLE DEVICE 54

12.15 SECURITY CONFIGURATION 55

12.16 CHIPSET SUB-MENU..... 56

12.17 NORTHBRIDGE CONFIGURATION 57

12.18 SOUTHBRIDGE CONFIGURATION 58

12.19 ISA CLOCK SETTINGS..... 59



Tri-M Technologies Inc.
 1407 Kebet Way, Unit 100
 Port Coquitlam, BC V3C 6L3
 Canada

Tel: 800.665.5600, 604.945.9565
 Fax: 604.945.9566
 E-mail: info@tri-m.com
 Web site: www.tri-m.com

12.20 SERIAL/PARALLEL PORTS CONFIGURATION 60
12.21 WATCHDOGS CONFIGURATION 62
12.22 MULTI-FUNCTION PORTS SUB-MENU 63
12.23 GPCS CONFIGURATION..... 72
12.24 REDUNDANCY PORT CONFIGURATION 73
12.25 EXIT OPTIONS 75

CHAPTER 13: LITERATURE REFERENCES..... 76

13.1 ISA SYSTEM ARCHITECTURE 76
13.2 AT BUS DESIGN..... 76
13.3 PERSONAL COMPUTER BUS STANDARD P996..... 76
13.4 PC INTERRUPTS..... 76
13.5 PC/104 CONSORTIUM..... 76



Tri-M Technologies Inc.
1407 Kebet Way, Unit 100
Port Coquitlam, BC V3C 6L3
Canada

Tel: 800.665.5600, 604.945.9565
Fax: 604.945.9566
E-mail: info@tri-m.com
Web site: www.tri-m.com

CHAPTER 1: GENERAL DESCRIPTION

The VDX104 is a PC104 or PC/104+ compliant system controller measuring just 3.55 inches by 3.775 inches. The VDX104 offers the quickest route of integrating a full x86 AT-compatible computer into your embedded control application using the PC/104 or PC/104+ form factor. In addition, the built-in peripherals minimize the number of additional modules required. By combining the system hardware, I/O, software (integrated OS image) and solid-state mass storage, the VDX104 lowers your exposure to possible development risks, costs and significantly reduces your time-to-market.

The VDX104's full compatibility with the popular PC/104 or PC/104+ embedded expansion bus allows you to easily integrate the widest selection of low-cost hardware peripherals. The numerous features provide an ideal price/performance solution.

Models available:

VDX104-1E: Base model for PC/104 bus

VDX104+1E: Base model for PC/104+ bus

VDX104+2E: Dual ethernet, 8MB on-board SPI flash, micro-SD reader, USB device port and PC/104+ bus

1.1 Specifications/Features

1.1.1 Vortex86DX

- Fully 486 compatible core running at 800 MHz.
- Six stage pipe-line.
- Integrated 16KB L1 instruction cache, 16KB L1 data cache.
- Integrated 4-ways 256KB L2 Cache.

1.1.2 Memory

- On-board 512MB.
- Dual Data Rate II 600MHz.

1.1.3 RS232 Interface

- Four full signaled external RS232 ports.
- All ports support up to 115200 baud.

1.1.4 Universal Serial Bus Interface

- Two host ports USB2.0 high speed.
- One on-board USB2.0 extension module.
- One device port USB1.1 (VDX104+2E only).

1.1.5 Ethernet Interface

- One on-chip 10/100 BaseT Fast Ethernet Controller.
- One additional Intel 82551er 10/100 BaseT Fast Ethernet Controller (VDX104+2E only).



Tri-M Technologies Inc.
1407 Kebet Way, Unit 100
Port Coquitlam, BC V3C 6L3
Canada

Tel: 800.665.5600, 604.945.9565
Fax: 604.945.9566
E-mail: info@tri-m.com
Web site: www.tri-m.com

1.1.6 Parallel Interface

- One enhanced bi-directional parallel port.
- Supports SPP, ECP and EPP.

1.1.7 Keyboard/Mouse Interface

- Supports AT keyboard and PS/2 mouse.

1.1.8 Enhanced IDE Interface

- One enhanced IDE channel, supports up to two drives (master/slave).
- Ultra DMA and PIO modes (1-4) support.

1.1.9 On board backup battery

- Keeps RTC running and CMOS data when the board is unpowered.

1.1.10 Expansion BUS - PC/104+ signals

- Fully compliant 16-bits PC/104 Expansion BUS.
- Fully compliant 32-bits PCI-104 Expansion BUS (VDX104+1E and VDX104+2E only).

1.1.11 Flash Storage

- On-board Compact Flash socket (shared with IDE Primary Master).
- On-board Micro-SDHC socket (VDX104+2E only).
- On-board 8MB SPI Flash (VDX104+2E only).

1.1.12 Jumperless configuration

- No hardware jumper required.
- Entirely configurable through the BIOS setting.

1.1.13 Software Compatibility

- Linux.
- Windows CE, XP, XPe.
- DOS.

1.1.14 Mechanical/Environmental

- PC/104+ form factor compliant, 3.55" x 3.775" x 0.9" (90mm x 96mm x 23mm).
- Standard with PC/104 16-bit stackthrough connector for PC/104-compliant modules.
- Operating temperature: -40° to 185°F (-40° to 85°C).
- Storage temperature: -58° to 257°F (-50° to 125°C).
- Weight: 0.13 lb (59 g) for the VDX104-1E.
- Weight: 0.16 lb (72 g) for the VDX104+1E.
- Weight: 0.17 lb (76 g) for the VDX104+2E.



CHAPTER 2: INSTALLATION

2.1 Locating the top connectors

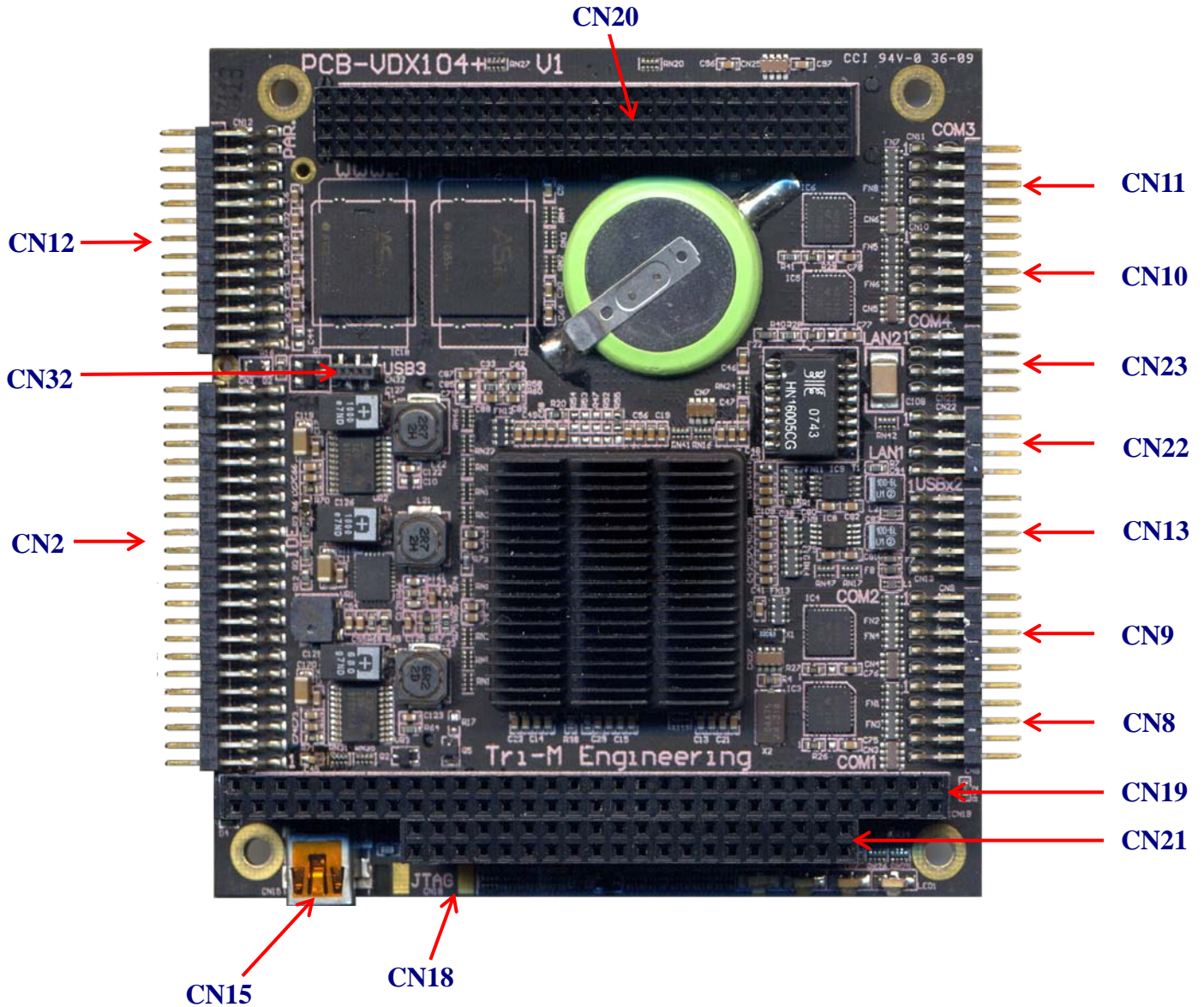

Figure 1: VDX104 top connector location.

2.2 Locating the bottom connectors

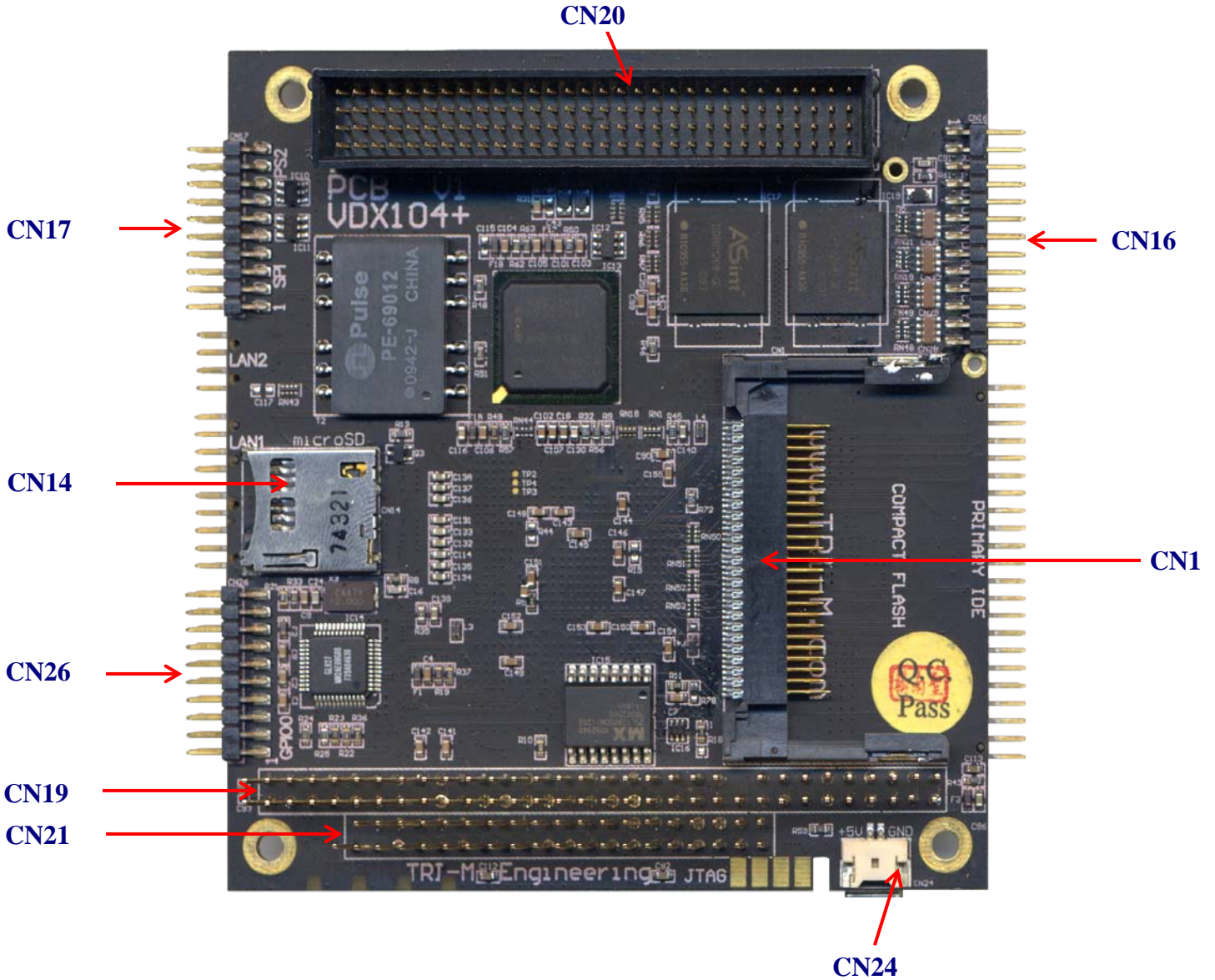

Figure 2: VDX104 bottom connector location.

CHAPTER 3: JUMPERS

NOT APPLICABLE

The VDX104 is jumperless, all the configuration is done through software.



Tri-M Technologies Inc.
1407 Kebet Way, Unit 100
Port Coquitlam, BC V3C 6L3
Canada

Tel: 800.665.5600, 604.945.9565
Fax: 604.945.9566
E-mail: info@tri-m.com
Web site: www.tri-m.com

CHAPTER 4: CONNECTORS

Connectors on the VDX104 are provided to interface external devices such as a Compact Flash, hard disk drive, microSD, Serial ports, Parallel port, USB, LAN, SPI, Mouse, keyboard, GPIO...

VDX104 Connector List	
Connector Label	Function
CN1	Compact Flash socket
CN2	IDE Interface
CN8	Serial port COM1
CN9	Serial port COM2
CN10	Serial port COM4
CN11	Serial port COM3
CN12	Parallel port
CN13	Dual USB 2.0
CN14	MicroSD socket (VDX104+2E only)
CN15	USB 1.1 device port (VDX104+2E only)
CN16	Redundancy port and I ² C
CN17	PS/2 and SPI
CN18	JTAG port
CN19	PC/104 8 bits BUS
CN20	PC/104+ 32 bits BUS (VDX104+1E & VDX104+2E only)
CN21	PC/104 16 bits BUS
CN22	LAN Interface 1
CN23	LAN Interface 2 (VDX104+2E only)
CN24	Input power +5VDC
CN26	GPIO port 0
CN32	On-board USB 2.0 extension module

Table 1: VDX104 Connector List



4.1 Compact Flash Socket (CN1)

The VDX104 embeds a Compact Flash socket directly interfaced to the ATA BUS allowing the Compact Flash to be detected as Hard-drive without additional software driver. The Compact Flash socket is configured as Primary Master therefore the Primary Master is no longer available on the ATA BUS connector when the Compact Flash is inserted. Another IDE device can still be used together with the Compact Flash if configured as Slave. The Compact Flash can be used to boot an Operating System or as a storage device.

Compact Flash Socket (CN1)			
Pin #	Signal	Pin #	Signal
1	GND	2	D03
3	D04	4	D05
5	D06	6	D07
7	CS0#	8	GND
9	GND	10	GND
11	GND	12	GND
13	VCC	14	GND
15	GND	16	GND
17	GND	18	A02
19	A01	20	A00
21	D00	22	D01
23	D02	24	NC
25	GND	26	GND
27	D11	28	D12
29	D13	30	D14
31	D15	32	CS1#
33	GND	34	IORD#
35	IOWR#	36	NC
37	INTRQ	38	VCC
39	CSEL#	40	NC
41	RESET#	42	IORDY
43	INPACK#	44	REG#
45	DASP#	46	PDIAG#
47	D08	48	D09
49	D10	50	GND

Table 2: Compact Flash Interface



4.2 IDE Interface (CN2)

The VDX104 carries an IDE interface compatible with the ATA/ATAPI-6 specification handling up to two devices, one Master and one Slave (Compact Flash socket included). The interface supports the PIO modes 0 to 4 with flow control, the DMA 0 to 2 and the ultra DMA 0 to 6.

IDE Interface (CN2)			
TOP		BOTTOM	
Pin #	Signal	Pin #	Signal
1	IDERST#	2	GND
3	IDED7	4	IDED8
5	IDED6	6	IDED9
7	IDED5	8	IDED10
9	IDED4	10	IDED11
11	IDED3	12	IDED12
13	IDED2	14	IDED13
15	IDED1	16	IDED14
17	IDED0	18	IDED15
19	GND	20	NC
21	IDEREQ	22	GND
23	IDEIOW#	24	GND
25	IDEIOR#	26	GND
27	IDERDY	28	GND
29	IDEACK	30	GND
31	IDEIRQ	32	NC
33	IDEA1	34	IDECBLID
35	IDEA0	36	IDEA2
37	IDECS0#	38	IDECS1#
39	IDELED	40	GND
41	+5VDC	42	+5VDC
43	GND	44	NC

Table 3: IDE Interface



4.3 Serial Ports RS232 (CN8, CN9, CN10 and CN11)

The VDX104 provides four PC-compatible asynchronous serial ports. All the serial ports can be enabled or disabled in through the BIOS setting, they can also be reconfigured to alternate I/O addresses and Interrupts.

RS232 Interface (CN8, CN9, CN10, CN11)			
TOP		BOTTOM	
Pin #	Signal	Pin #	Signal
1	DCD	2	DSR
3	RX	4	RTS
5	TX	6	CTS
7	DTR	8	RI
9	GND	10	FORCE C.R. ON

Table 4: RS232 Ports

4.4 Parallel Port (CN12)

The VDX104 incorporates one IBM XT/AT compatible parallel port. It can be configured as bi-directional parallel port (SPP), enhanced parallel port (EPP) and extended capabilities parallel port (ECP) through the BIOS setting. The base address and the interrupts can also be configured or disabled.

Parallel Port (CN12)			
TOP		BOTTOM	
Pin #	Signal	Pin #	Signal
1	STRB#	2	AUTOFD#
3	PD0	4	ERR#
5	PD1	6	INIT#
7	PD2	8	SLCTIN#
9	PD3	10	GND
11	PD4	12	GND
13	PD5	14	GND
15	PD6	16	GND
17	PD7	18	GND
19	ACK#	20	GND
21	BUSY	22	GND
23	PE	24	GND
25	SLCT	26	GND

Table 5: Parallel Port



4.5 Universal Serial Bus (CN13)

The VDX104 provides two USB2.0 ports (USB0 and USB1). The USB 2.0 controller is a two-port host controller which contains one OHCI host controller and one EHCI host controller. Both ports support up to 127 devices at low-speed (1.5MHz), full-speed (12MHz) and high-speed (480MHz).

USB Host Interface (CN13)			
TOP		BOTTOM	
Pin #	Signal	Pin #	Signal
1	+5VDC	2	GND ISO
3	DATA-	4	GND
5	DATA+	6	DATA+
7	GND	8	DATA-
9	GND ISO	10	+5VDC

Table 6: USB Ports

4.6 MicroSD Socket (CN14) VDX104+2E only

The VDX104+2E embeds a MicroSD socket interfaced to the internal USB2 port through a USB 2.0 card reader controller allowing the media to be detected as USB storage device. The MicroSD can be used to boot an Operating System or as a storage device.

MicroSD Socket (CN14)			
Pin #	Signal	Pin #	Signal
1	DATA2	2	DATA3
3	CMD	4	VCC
5	CLK	6	GND
7	DATA0	8	DATA1

Table 7: MicroSD Interface



4.7 USB Device Port (CN15) VDX104+2E only

The VDX104+2E embeds a USB device port connector allowing the unit to be used as a USB device.

USB Device Port (CN15)	
Pin #	Signal
1	+5VDC
2	DATA-
3	DATA+
4	NC
5	GND

Table 9: USB Device Port

4.8 Redundancy Port and I²C (CN16)

The redundancy port of the VDX104 provides the communication port and the control signals to interconnect two CPU boards together. It allows the CPU boards to exchange data and share buses and devices. The connector also carry an I²C bus

Redundancy Port (CN16)	
BOTTOM	
Pin #	Signal
1	GND
2	I ² C SCL
3	I ² C SDA
4	SYS-FAIL-OUT
5	MTBF-OUT
6	GPCS1
7	GPCS0
8	SYS-FAIL-IN
9	SYS-SW-IN
10	SYS-GPCS-IN
11	COM9 TX
12	COM9 RX
13	RESET / PWRGD

Table 8: Redundancy Port



4.9 PS/2-SPI Port (CN17)

The PS/2-SPI port of the VDX104 provides connections for PS/2 Keyboard, PS/2 Mouse and external SPI devices.

PS/2-SPI Port (CN17)	
BOTTOM	
Pin #	Signal
1	SPI-DO
2	SPI-DI
3	SPI-CLK
4	SPI-CS
5	PS/2 MS DATA
6	PS/2 MS CLK
7	PS/2 KB DATA
8	PS/2 KB CLK
9	+5VDC
10	GND

Table 9: PS/2-SPI Port



4.10 JTAG Port (CN18)

This port can be used to re-program the BIOS when the internal flash is erased.

JTAG port (CN18)			
TOP		BOTTOM	
Pin #	Signal	Pin #	Signal
1	+3VDC	2	TCK
-	-	3	TDO
-	-	4	TDI
6	GND	5	TMS

Table 10: JTAG Port



4.11 PC/104 BUS (CN19 and CN21)

Both CN19 and CN21 provide the flexibility to attach PC/104 expansion modules to the VDX104. These modules perform the functions of traditional ISA add-on cards in a PC environment. The bus also provides the main power input +5V.

PC/104 8-bit Connector (CN19)			
Pin #	Signal	Pin #	Signal
A1	IOCHCK	B1	GND
A2	SD7	B2	RESETDRV
A3	SD6	B3	+5V
A4	SD5	B4	IRQ9
A5	SD4	B5	NC
A6	SD3	B6	DRQ2
A7	SD2	B7	NC
A8	SD1	B8	OWS
A9	SD0	B9	NC
A10	IOCHRDY	B10	KEY
A11	AEN	B11	SMEMW
A12	SA19	B12	SMEMR
A13	SA18	B13	IOW
A14	SA17	B14	IOR
A15	SA16	B15	DACK3
A16	SA15	B16	DRQ3
A17	SA14	B17	DACK1
A18	SA13	B18	DRQ1
A19	SA12	B19	REFRESH
A20	SA11	B20	ISACLK
A21	SA10	B21	IRQ7
A22	SA9	B22	IRQ6
A23	SA8	B23	IRQ5
A24	SA7	B24	IRQ4
A25	SA6	B25	IRQ3
A26	SA5	B26	DACK2
A27	SA4	B27	TC
A28	SA3	B28	BALE
A29	SA2	B29	+5V
A30	SA1	B30	14MHz
A31	SA0	B31	GND
A32	GND	B32	GND

Table 11: PC/104 8-bit Interface



PC/104 16-bit Connector (CN21)			
Pin #	Signal	Pin #	Signal
C0	GND	D0	GND
C1	SBHE	D1	MEMCS16
C2	LA23	D2	IOCS16
C3	LA22	D3	IRQ10
C4	LA21	D4	IRQ11
C5	LA20	D5	IRQ12
C6	LA19	D6	IRQ15
C7	LA18	D7	IRQ14
C8	LA17	D8	DACK0
C9	MEMR	D9	DRQ0
C10	MEMW	D10	DACK5
C11	SD8	D11	DRQ5
C12	SD9	D12	DACK6
C13	SD10	D13	DRQ6
C14	SD11	D14	DACK7
C15	SD12	D15	DRQ7
C16	SD13	D16	+5V
C17	SD14	D17	MASTER
C18	SD15	D18	GND
C19	KEY	D19	GND

Table 12: PC/104 16-bit Interface



Tri-M Technologies Inc.
 1407 Kebet Way, Unit 100
 Port Coquitlam, BC V3C 6L3
 Canada

Tel: 800.665.5600, 604.945.9565
 Fax: 604.945.9566
 E-mail: info@tri-m.com
 Web site: www.tri-m.com

4.12 PC/104+ BUS (CN20) VDX104+1E & VDX104+2E only

CN20 provides the flexibility to attach PCI-104 and/or PC/104+ expansion modules to the VDX104. These modules perform the functions of traditional PCI add-on cards in a PC environment. The bus also provides the main power input +5V. The CPU board does not supply the +3.3V to the bus, it has to be generated externally to power the PC/104+ devices.

PC/104+ 32-bit Connector (CN20)				
Pin #	A	B	C	D
1	GND	NC	+5V	AD00
2	NC	AD02	AD01	+5V
3	AD05	GND	AD04	AD03
4	CBE0	AD07	GND	AD06
5	GND	AD09	AD08	GND
6	AD11	NC	AD10	NC
7	AD14	AD13	GND	AD12
8	NC	CBE1	AD15	NC
9	SERR	GND	NC	PAR
10	GND	PERR	NC	NC
11	STOP	NC	LOCK	GND
12	NC	TRDY	GND	DEVSEL
13	FRAME	GND	IRDY	NC
14	GND	AD16	NC	CBE2
15	AD18	NC	AD17	GND
16	AD21	AD20	GND	AD19
17	NC	AD23	AD22	NC
18	IDSEL0	GND	IDSEL1	IDSEL2
19	AD24	CBE3	NC	IDSEL3
20	GND	AD26	AD25	GND
21	AD29	+5V	AD28	AD27
22	+5V	AD30	GND	AD31
23	NC	GND	REQ1	NC
24	GND	REQ2	+5V	NC
25	GNT1	NC	GNT2	GND
26	+5V	CLK0	GND	CLK1
27	CLK2	+5V	CLK3	GND
28	GND	INTD	+5V	PCIRST
29	NC	INTA	INTB	INTC
30	NC	NC	NC	GND

Table 13: PC/104+ 32-bit Interface



Tri-M Technologies Inc.
 1407 Kebet Way, Unit 100
 Port Coquitlam, BC V3C 6L3
 Canada

Tel: 800.665.5600, 604.945.9565
 Fax: 604.945.9566
 E-mail: info@tri-m.com
 Web site: www.tri-m.com

4.13 LAN Interface 1 (CN22)

The VDX104 is equipped with an Ethernet 10/100 BaseT. It provides 32 bit performance, PCI bus master capability and full compliance with IEEE 802.3u specifications. It supports 10Mbps and 100 Mbps N-way auto-negotiation operation and full duplex flow control compliant with IEEE 802.3x

LAN interface 1 (CN22)			
TOP		BOTTOM	
Pin #	Signal	Pin #	Signal
1	TX+	2	TX-
3	RX+	4	NC
5	NC	6	RX-
7	NC	8	NC

Table 14: LAN Interface 1

4.14 LAN Interface 2 (CN23) VDX104+2E only

The VDX104+2E embeds an Intel 82551er Ethernet controller that provides an additional Ethernet 10/100 BaseT. It is interfaced through the 32 bit PCI bus and has bus master capability. It supports full duplex at 10Mbps and 100 Mbps and it has IEEE 802.3u auto-negotiation support. The flow control is compliant with IEEE 802.3x.

LAN interface 2 (CN23)			
TOP		BOTTOM	
Pin #	Signal	Pin #	Signal
1	TX+	2	TX-
3	RX+	4	NC
5	NC	6	RX-
7	NC	8	NC

Table 15: LAN Interface 2



4.15 Input Power (CN24)

The VDX104 can be powered by supplying 5VDC and ground to CN24. Alternatively, the VDX104 can be powered by supplying 5VDC through the PC104 connector (CN19 + CN21) with a PC104 power supply such as the Tri-M Technologies Inc. HE104 or HESC-104.

External Power (CN24)	
Pin #	Signal
1	+5VDC
2	GND

Table 16: Power connector



This is not a wide range input, a voltage exceeding +5VDC or a reverse polarity will cause damage to the board.



4.16 GPIO 0 Port (CN26)

The GPIO 0 port of the VDX104 provides 8 input/output signals and a 5VDC supply to ease interfacing with external circuitry. The GPIO0 port can be configured through the BIOS settings or through I/O registers. Each bit can be programmed as input or output independently.

GPIO 0 Port (CN26)	
BOTTOM	
Pin #	Signal
1	GPIO0-bit0
2	GPIO0-bit1
3	GPIO0-bit2
4	GPIO0-bit3
5	GPIO0-bit4
6	GPIO0-bit5
7	GPIO0-bit6
8	GPIO0-bit7
9	+5VDC
10	GND

Table 17: GPIO 0 Port

4.17 On-board USB 2.0 extension module (CN32)

The on-board USB 2.0 socket is design to enhance the VDX104 cpu board using an USB2.0 port. It allows to connect modules with a variety of features directly to the CPU board. The module can be mechanically secured using two screws.

On-Board USB socket (CN32)	
Pin #	Signal
1	GND
2	DATA+
3	DATA-
4	+5VDC
5	+3.3VDC

Table 18: On-board USB socket



CHAPTER 5: GENERAL PURPOSE INPUT/OUTPUT

5.1 Overview

The VDX104 provides many GPIO signals. Some are wired to the Redundancy connector (CN16) or the GPIO 0 port (CN26) and are free for personal use. Others are used to control some of the board settings. The direction register and the data register of both ports will have to be set to match the desired configuration. If all GPIO signals used for devices configuration are configured as input, the industry default setting will be applied.

5.2 GPIO Port 0

The GPIO port 0 bits 0 to 7 are wired to the GPIO 0 connector (CN26). They are free and can be used for personal use. As input these pins are pulled high with a 75KΩ pull-up and are 5 Volt tolerant. As output these pins can drive 8mA.

Direction register, Address: 0x98

Bit	7	6	5	4	3	2	1	0
Function	CN26 Pin8	CN26 Pin7	CN26 Pin6	CN26 Pin5	CN26 Pin4	CN26 Pin3	CN26 Pin2	CN26 Pin1

Table 19: GPIO 0 Direction Register

The Default value is 0x00 (all signals set as input), programming a bit to 1 change the configuration of the corresponding pin to output. This register can be configured through the BIOS settings.



These pins are directly connected to the processor, applying too much voltage or draining too much current could damage it.



Data register, Address: 0x78

Bit	7	6	5	4	3	2	1	0
Function	CN26 Pin8	CN26 Pin7	CN26 Pin6	CN26 Pin5	CN26 Pin4	CN26 Pin3	CN26 Pin2	CN26 Pin1

Table 20: GPIO 0 Data Register

When configured as input the bit will reflect the TTL level applied to the pin. When configured as output a 0 set the pin to 0 Volt and a 1 set the pin to 3.3 Volt.



5.3 GPIO Port 1

The GPIO port 1 allows control of the RS232 transceiver of all the serial ports (COM1 to COM4). It also reports if a valid RS232 signal is applied to any of the serial ports.

Direction register, Address: 0x99

Bit	7	6	5	4	3	2	1	0
Function	COM4 Status	COM3 Status	COM2 Status	COM1 Status	COM4 PME	COM3 PME	COM2 PME	COM1 PME

Table 21: GPIO 1 Direction Register

The Default value is 0x00 (all signals set as input), all the serial ports have the power management disabled. Changing bits 0-3 to 1 allows control of the power management of the corresponding serial port through the data register.



Setting bits 4 TO 7 as output, could cause damage to the board because the signals will be in conflict with the transceiver output.



Data register, Address: 0x79

Bit	7	6	5	4	3	2	1	0
Function	COM4 Status	COM3 Status	COM2 Status	COM1 Status	COM3 PME	COM3 PME	COM2 PME	COM1 PME

Table 22: GPIO 1 Data Register

Status bit return 1 when a valid RS232 level is detected on the corresponding serial port.

PME bit set to 1 to force ON the transceiver of the corresponding serial port.

PME bit set to 0 to have the transceiver of the corresponding serial port to turning ON only when RS232 signal present.



5.4 GPIO Port 2

The GPIO port 2 allows control of the power switches of the USB ports (USB0 and USB1), ability to read the over current status of the USB ports (USB0 and USB1), select the Compact Flash socket to Master or Slave, and read/control the power management of the PCI devices.

Direction register, Address: 0x9A

Bit	7	6	5	4	3	2	1	0
Function	μSD WP	SPI SEL	USB1 OVC	USB0 OVC	LEDs enable	N.U.	USB1 enable	USB0 enable

Table 23: GPIO 2 Direction Register

The Default value is 0x00 (all signals set as input), both USB ports (0 and 1) are enabled, the Compact Flash socket is configured as Slave and the on-board LED's are turned on.

Changing bits 0-1 to 1 allows control of the power switch of the corresponding USB port through the data register. Changing bit 3 to 1 allows to turn ON/OFF the on-board LEDs through the data register. Changing the bit 6 to 1 allows to selection for the SPI port to be used internally or externally. Changing bit 7 to 1 allows to write protect the on-board Micro-SD through the data register.



Setting bits 4 and 5 as output could cause damage to the board because the signals will be in conflict with the USB switch output.



Data register, Address: 0x7A

Bit	7	6	5	4	3	2	1	0
Function	μSD WP	SPI SEL	USB1 OVC	USB0 OVC	LEDs enable	N.U.	USB1 enable	USB0 enable

Table 24: GPIO 1 Data Register

USB enable return 1 when the power switch is turned ON and 0 when the switch is turned OFF.

USB OVC bit return 0 the USB device of the corresponding port is draining too much current.

SPI SEL: set to 0 to access the on board SPI flash, set to on to access external device.

LEDs enable return 1 when the on-board LEDs are turned OFF.

μSD WP return 1 when WRITE PROTECTED.

5.5 GPIO Port 3

The GPIO port 3 bit 0 to 3 are wired respectively to the PS/2-SPI connector (CN17) pin 2, 1, 3, 4 and bit 4 to 5 are wired respectively to the redundancy connector (CN16) pin 2 and 3 . When set as GPIO they are free and can be used for personal use. The bit 0 to 3 can also be configured as an external SPI port. As input these pins are pulled high with a 75KΩ pull-up and are 5 Volt tolerant. As output these pins can drive 8mA.

Direction register, Address: 0x9B

Bit	7	6	5	4	3	2	1	0
Function	C.R. FON	USB DET	CN16 Pin3	CN16 Pin2	CN17 Pin2	CN17 Pin1	CN17 Pin3	CN17 Pin4

Table 25: GPIO 3 Direction Register

The Default value is 0x00 (all signals set as input), programming a bit to 1 changes the configuration of the corresponding pin to output. When the GPIO port 3 is set as SPI port, bits 4 and 5 can still be used as GPIO. When the GPIO port 3 is set as I²C port, bits 0 to 3 can still be used as GPIO. Do not change the bit 6 or 7 to output, it will prevent the BIOS to work properly. All the configuration of the ports can be done through the BIOS settings.



These pins are directly connected to the processor, applying too much voltage or draining too much current could damage it.



Data register, Address: 0x7B

Bit	7	6	5	4	3	2	1	0
Function	C.R. detect	USB DET	CN16 Pin3	CN16 Pin2	CN17 Pin2	CN17 Pin1	CN17 Pin3	CN17 Pin4

Table 26: GPIO 3 Data Register

CN16/CN17: when configured as input the bit will reflect the TTL level applied to the pin.
 CN16/CN17: when configured as output a 0 set the pin to 0 Volt and a 1 set the pin to 3.3 Volt.

USB DET: return 1 when the USB device port is connected (powered).
 C.R. Detect: return 0 when Console redirection forced ON, feature built into the BIOS.

GPIO port 3 bit 0 (CN17-Pin4) is shared with SPI-CS.
 GPIO port 3 bit 1 (CN17-Pin3) is shared with SPI-CLK.
 GPIO port 3 bit 2 (CN17-Pin1) is shared with SPI-DO.
 GPIO port 3 bit 3 (CN17-Pin2) is shared with SPI-DI.
 GPIO port 3 bit 4 (CN16-Pin2) is shared with I²C-SCL.
 GPIO port 3 bit 5 (CN16-Pin3) is shared with I²C -SDA.



Tri-M Technologies Inc.
 1407 Kebet Way, Unit 100
 Port Coquitlam, BC V3C 6L3
 Canada

Tel: 800.665.5600, 604.945.9565
 Fax: 604.945.9566
 E-mail: info@tri-m.com
 Web site: www.tri-m.com

5.6 GPIO Port 4

The GPIO port 4 is shared with the RS232 port 1. All the signals are wired to an RS232 transceiver and therefore have limitations as GPIO. We strongly suggest to keep this port configured as Serial port 1 to avoid any mis-configuration that could cause damage to the board.

Direction register, Address: 0x9C

Bit	7	6	5	4	3	2	1	0
Function	Input only	Input only	Output only	Input only	Input only	Output only	Output only	Input only

Table 27: GPIO 4 Direction Register

The Default value is 0x00 (all signals set as input), programming a bit to 1 change the configuration of the corresponding pin to output. All the configuration of the port can be done through the BIOS settings.



Any mis-configuration of the GPIO port 4 registers can damage the processor and/or the RS232 transceiver.



Data register, Address: 0x7C

Bit	7	6	5	4	3	2	1	0
Function	CN8 Pin6	CN8 Pin2	CN8 Pin7	CN8 Pin3	CN8 Pin8	CN8 Pin4	CN8 Pin5	CN8 Pin1

Table 28: GPIO 4 Data Register

The inputs will reflect the RS232 level applied to the pin.
The outputs will drive an RS232 level to the pin (-6V, 6V).

GPIO port 4 bit 0 (CN8-Pin1) is shared with Serial port 1 DCD.
GPIO port 4 bit 1 (CN8-Pin5) is shared with Serial port 1 TX.
GPIO port 4 bit 2 (CN8-Pin4) is shared with Serial port 1 RTS.
GPIO port 4 bit 3 (CN8-Pin8) is shared with Serial port 1 RI.
GPIO port 4 bit 4 (CN8-Pin3) is shared with Serial port 1 RX.
GPIO port 4 bit 5 (CN8-Pin7) is shared with Serial port 1 DTR.
GPIO port 4 bit 6 (CN8-Pin2) is shared with Serial port 1 DSR.
GPIO port 4 bit 7 (CN8-Pin6) is shared with Serial port 1 CTS.



CHAPTER 6: WATCHDOG TIMER

6.1 Overview

A watchdog is a device providing a system with a way to recover when the software is not responding. The circuitry is composed of a 24 bits counter incrementing at a rate of 32.768KHz and is supposed to be continuously cleared by the running software. When the software is not responding, the counter is not cleared and when it reaches a pre-programmed value, the circuitry will generate an interrupt or a system reset. The Vortex86DX embeds two watchdog timers.

6.2 WDT0 Registers

The WDT0 registers can be accessed through the index port 0x22 and the data port 0x23. These registers are used to configure the time out, to select the event generated and to clear the counter. The time out can be programmed from 30.5 µsec to 512 sec with a resolution of 30.5 µsec. The configuration of the watchdog 0 can be performed in the BIOS settings.

Index: 0x37

Bit	7	6	5	4	3	2	1	0
Function	X	EN	X	X	X	X	X	X

Table 29: WDT0 Enable Register

EN: set to 1 to enable the WDT0

Index: 0x38

Bit	7	6	5	4	3	2	1	0
Function	EVN3	EVN2	EVN1	EVN0	X	X	X	X

Table 30: WDT0 Event Register

EVN[3-0]	Signal	EVN[3-0]	Signal	EVN[3-0]	Signal	EVN[3-0]	Signal	EVN[3-0]	Signal
0001	IRQ3	0100	IRQ6	0111	IRQ10	1010	IRQ14	1101	RESET
0010	IRQ4	0101	IRQ7	1000	IRQ11	1011	IRQ15	0001	Rsvd
0011	IRQ5	0110	IRQ9	1001	IRQ12	1100	INMI	0001	Rsvd



Index: 0x39

Bit	7	6	5	4	3	2	1	0
Function	D7	D6	D5	D4	D3	D2	D1	D0

Table 31: WDT0 Counter Low

Index: 0x3A

Bit	7	6	5	4	3	2	1	0
Function	D15	D14	D13	D12	D11	D10	D9	D8

Table 32: WDT0 Counter Mid

Index: 0x3B

Bit	7	6	5	4	3	2	1	0
Function	D23	D22	D21	D20	D19	D18	D17	D16

Table 33: WDT0 Counter High

D[23-0]: WDT0 24 bits counter.

Index: 0x3C

Bit	7	6	5	4	3	2	1	0
Function	TO	CLR	X	X	X	X	X	X

Table 34: WDT0 Clear Register

CLR: Write 1 reset the watchdog timer.

TO: read only bit, set to 1 when the watchdog time out occurred.



6.3 WDT1 Registers

The WDT1 registers can be accessed through the I/O ports 0x68 to 0x6D. These registers are used to configure the time out, to select the event generated and to clear the counter. The time out can be programmed from 30.5 μ sec to 512 sec with a resolution of 30.5 μ sec. The configuration of the watchdog 1 can be performed in the BIOS settings.

Address: 0x68

Bit	7	6	5	4	3	2	1	0
Function	X	EN	X	X	X	X	X	X

Table 35: WDT1 Enable Register

EN: set to 1 to enable the WDT1

Address: 0x69

Bit	7	6	5	4	3	2	1	0
Function	EVN3	EVN2	EVN1	EVN0	X	X	X	X

Table 36: WDT1 Event Register

EVN[3-0]	Signal	EVN[3-0]	Signal	EVN[3-0]	Signal	EVN[3-0]	Signal	EVN[3-0]	Signal
0001	IRQ3	0100	IRQ6	0111	IRQ10	1010	IRQ14	1101	RESET
0010	IRQ4	0101	IRQ7	1000	IRQ11	1011	IRQ15	0001	Rsvd
0011	IRQ5	0110	IRQ9	1001	IRQ12	1100	INMI	0001	Rsvd

Address: 0x6A

Bit	7	6	5	4	3	2	1	0
Function	D7	D6	D5	D4	D3	D2	D1	D0

Table 37: WDT1 Counter Low



Address: 0x6B

Bit	7	6	5	4	3	2	1	0
Function	D15	D14	D13	D12	D11	D10	D9	D8

Table 38: WDT1 Counter Mid

Address: 0x6C

Bit	7	6	5	4	3	2	1	0
Function	D23	D22	D21	D20	D19	D18	D17	D16

Table 39: WDT1 Counter High

D[23-0]: WDT1 24 bits counter.

Address: 0x6D

Bit	7	6	5	4	3	2	1	0
Function	TO	CLR	X	X	X	X	X	X

Table 40: WDT1 Clear Register

CLR: Write 1 reset the watchdog timer.

TO: read only bit, set to 1 when the watchdog time out occurred.



CHAPTER 7: CMOS RAM

7.1 Overview

The CMOS RAM is a 128 bytes memory part of the RTC circuitry powered by the battery. This memory is usually used by the system to store the BIOS settings, the date and time. The Vortex86DX has 20 bytes of this memory reserved for customization. These 20 bytes are free for use and are not part of the checksum calculation.

7.2 CMOS RAM mapping

The CMOS RAM can be accessed through the index port 0x70 and the data port 0x71.

Index 0x70	Data 0x71
0x00 ~ 0x4B	BIOS Settings
0x4C ~ 0x5F	Free Space
0x60 ~ 0x7F	BIOS Settings

Table 41: CMOS RAM mapping



Index 0x00 to 0x4B and 0x60 to 0x7F are used by the system, any change in this area may cause the system to crash or work abnormally.



CHAPTER 8: REDUNDANCY

8.1 Overview

The Vortex86DX embeds some additional circuitry allowing two system boards to be connected together for redundancy purposes. This circuitry is composed of additional tri-state buffers allowing some buses and devices to be interconnected, extra logic to control these buffers and the systems status and communication channels to exchange information between both systems.

8.2 Block diagram

The following diagram shows how the system CPU can be interconnected. The logic and communication ports are interconnected to signal the other CPU when a fail state occurs and to keep the data up to date on both CPUs.

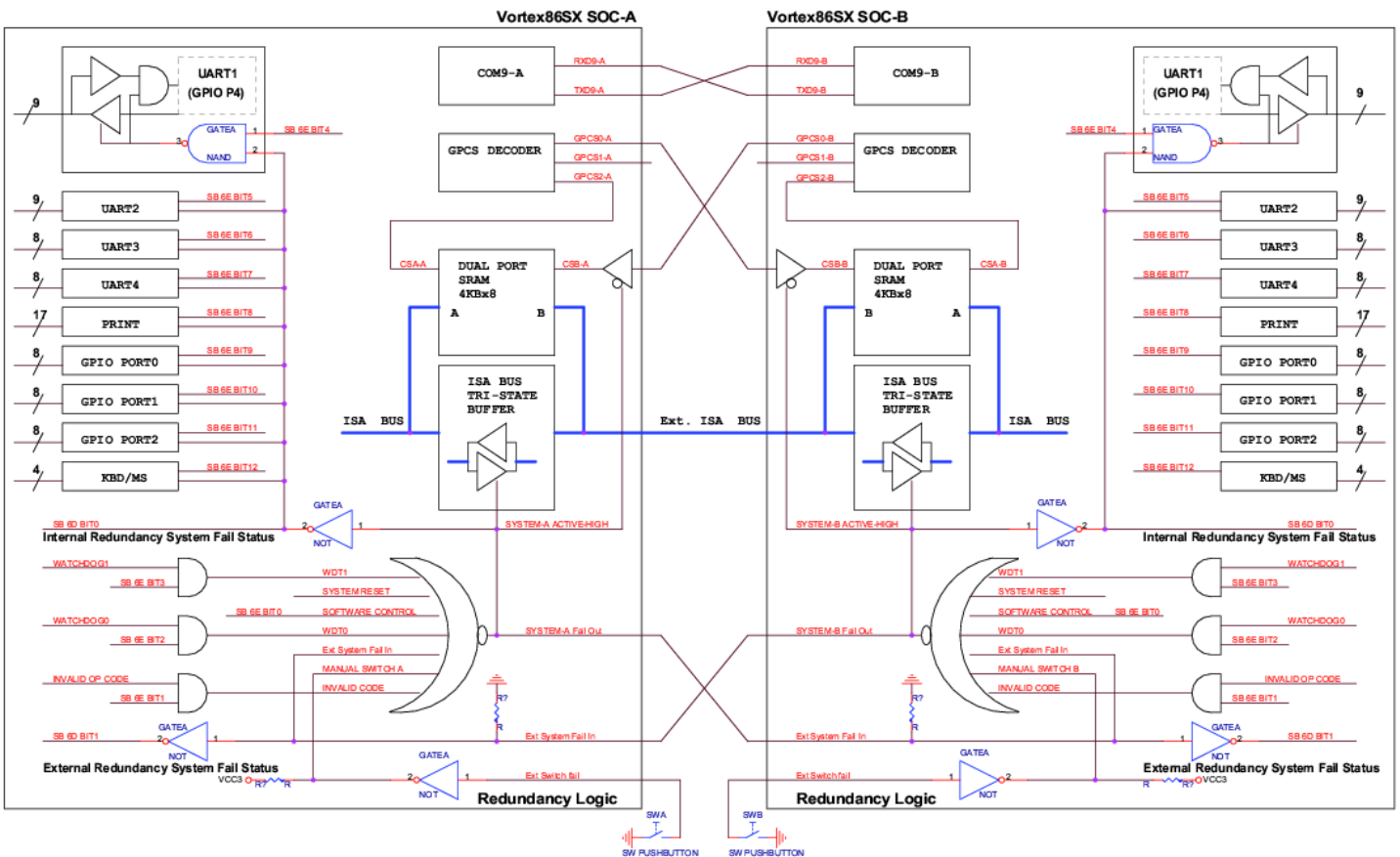

Vortex86SX Redundancy System Block Diagram



8.3 Tri-stated Devices

To allow two CPUs to control the same devices, an isolation circuitry has to be put in place to avoid any conflict that cause damage to the system. The Vortex86DX has several ports protected with tri-state buffers. These ports are the four UARTs, the parallel port, the GPIO ports 0 to 2, the PS/2 interface and the entire PC/104 bus. Additionally the VDX104 will turn off automatically all the RS232 transceivers when the output fail signal is set.

8.4 System intercommunication

For a redundant system to work both CPUs need to know what is the global status of the system, the spare CPU needs to know what the running CPU is doing at any moment. To do so both CPUs need to exchange data. The Vortex86DX has two communication ports dedicated to the redundancy port, one serial port and one dual port SRAM accessible through the PC104 bus outside the tri-state buffer. This SRAM can be accessed internally and externally to allow data exchange between both CPUs.



Tri-M Technologies Inc.
1407 Kebet Way, Unit 100
Port Coquitlam, BC V3C 6L3
Canada

Tel: 800.665.5600, 604.945.9565
Fax: 604.945.9566
E-mail: info@tri-m.com
Web site: www.tri-m.com

CHAPTER 9: ONBOARD SPI FLASH (VDX104+2E only)

9.1 Overview

The VDX104 version 3 embeds a 2MBytes SPI flash supported by the BIOS as floppy drive. The BIOS performs a floppy emulation over the SPI allowing an OS relying on the BIOS like DOS to access it as if it was a real floppy. OS not relying on the BIOS like Linux will need a driver to support the feature. The size of the flash is entirely accessible, it is not limited to 1.44MB. This feature can be enabled through the BIOS settings (see Chapter 12: BIOS).

9.2 SPITool

When enabled in the BIOS, the SPI flash should be directly accessible in DOS. However, not every version of DOS is able to always format it properly. As a workaround DMP provides a tool called "spitool.exe" allowing you to format it properly under any version of DOS. This tool is also able to erase the flash, save the content of the SPI flash to a file and re-load an SPI flash from a file image.

SPITool FORMAT

Initialize the SPI flash and format it using FAT.

SPITool ERASE

Erase the entire content of the SPI flash, the flash will content only 0xFF.

SPITool READ FILENAME

Read entire the content of the SPI flash and save into a file.

SPITool WRITE FILENAME

Write the content of a file into the SPI flash.

CHAPTER 10: ONBOARD LED's



Tri-M Technologies Inc.
1407 Kebet Way, Unit 100
Port Coquitlam, BC V3C 6L3
Canada

Tel: 800.665.5600, 604.945.9565
Fax: 604.945.9566
E-mail: info@tri-m.com
Web site: www.tri-m.com

10.1 Overview

The VDX104 version 3 embeds three bi-color LED's displaying system status and devices activities. The LED's can be disabled to reduce the power consumption of the board (see Chapter 12: BIOS).

10.2 LED1

The LED1 a bi-color GREEN-RED and it is use to display the status of the PWRGOOD signal and the activity of the IDE controller.

The LED is steady green when all the on-board power are good (V_{core} , 1.8V and 3.3V) and the master reset is released (PWRGOOD signal inserted).

The LED is steady green and flashing red when the IDE interface is accessed, Hard-drive and/or Compact Flash.

10.3 LED2 (VDX104+2E only)

The LED2 is bi-color BLUE-RED and it is use to display the status of the on-board Micro-SD interface.

The LED is steady red when there is no Micro-SD inserted into the slot.

The LED is steady blue when there is a Micro-SD inserted into the slot.

The LED is steady blue and flashing red when Micro-SD is accessed, in reading or writing.

10.4 LED3

The LED3 is bi-color GREEN-YELLOW and it is use to display the status of the first on-board Ethernet controller (built-in Ethernet controller of the Vortex86DX CPU).

The LED is steady green when there is network link.

The LED is steady green and flashing yellow when there is network activities.

10.5 LED4 (VDX104+2E only)

The LED4 is bi-color GREEN-YELLOW and it is use to display the status of the second on-board Ethernet controller (on-board Intel Ethernet controller 82551IT).

The LED is steady green when there is network link.

The LED is steady green and flashing yellow when there is network activities.

CHAPTER 11: CONSOLE REDIRECTION

11.1 Overview



Tri-M Technologies Inc.
1407 Kebet Way, Unit 100
Port Coquitlam, BC V3C 6L3
Canada

Tel: 800.665.5600, 604.945.9565
Fax: 604.945.9566
E-mail: info@tri-m.com
Web site: www.tri-m.com

When the VSX104 is not equipped with video card, the display can be redirected to one of the serial port. The console redirection can be enabled and configured through the BIOS settings (see Chapter 12: BIOS). In addition when the console redirection is disabled in the BIOS settings and no video card are available, the console redirection can be forced ON by connecting the pin#10 of one of the serial ports to ground (see Chapter 4: CONNECTORS).

11.2 Force Console Redirection ON

Even when disabled in the BIOS settings, the console redirection can be forced ON using a console redirection cable or by connecting pin#10 of any serial port to ground.

The console won't automatically be enabled to the selected serial port but will follow the BIOS settings.

As example: if the pin#10 of COM4 is grounded but the console redirection is configured to COM1 in the BIOS settings, the console redirection will be assigned to COM1.

11.3 Default settings

Remote Access: Disabled (will be override when pin#10 grounded).

Serial port number: COM1.

Base Address, IRQ: 3F8h, 4.

Serial Port Mode: 115200 8,N,1.

Flow Control: none.

Redirection after POST: Always.

Terminal type: ANSI.

VT-UTF8 Combo Key: Enabled.

Sredir Memory Display Delay: No Delay.



Any change applied to the console redirection configuration will be used when forcing it ON.



CHAPTER 12: BIOS

12.1 Main menu

```

Main      Advanced  PCIPnP    Boot      Security  Chipset   Exit
*****
* System Overview                                     *
* *****                                           *
* Processor                                           *
* Vortex A9121                                       *
* Speed      :800MHz                                   *
*                                                    *
* System Memory                                       *
* Size       :512MB                                   *
* Speed      :300MHz                                   *
*                                                    *
* System Time                                     [01:25:47] *
* System Date                                     [Sun 05/28/2010] *
*                                                    *
*                                                    * *      Select Screen *
*                                                    * **     Select Item   *
*                                                    * +-    Change Field  *
*                                                    * Tab   Select Field  *
*                                                    * F1    General Help  *
*                                                    * F10   Save and Exit *
*                                                    * ESC   Exit          *
*                                                    *
*****
v02.58 (C)Copyright 1985-2008, American Megatrends, Inc.
    
```

Figure 3: Main menu.

The Main page provides the system overview:

- ☞ The CPU model and speed.
- ☞ The memory size and bus speed.
- ☞ The time setting of the RTC.
- ☞ The date setting of the RTC.



Tri-M Technologies Inc.
 1407 Kebet Way, Unit 100
 Port Coquitlam, BC V3C 6L3
 Canada

Tel: 800.665.5600, 604.945.9565
 Fax: 604.945.9566
 E-mail: info@tri-m.com
 Web site: www.tri-m.com

12.2 Advanced Settings

```

Main      Advanced  PCIPnP    Boot      Security  Chipset   Exit
*****
* Advanced Settings                                     * Configure the IDE *
* ****                                     * device(s).       *
* WARNING: Setting wrong values in below sections    *                 *
*      may cause system to malfunction.              *                 *
*                                                     *                 *
* * CPU Configuration                                  *                 *
* * IDE Configuration                                  *                 *
* * Remote Access Configuration                       *                 *
* * USB Configuration                                  *                 *
*                                                     *                 *
* SB LAN                                             [Enabled]         *
* MAC Address                                         [00 07 1E 60 00 2B] *
*                                                     * **      Select Screen *
*                                                     * **      Select Item   *
*                                                     * Enter Go to Sub Screen *
*                                                     * F1      General Help   *
*                                                     * F10     Save and Exit  *
*                                                     * ESC     Exit           *
*                                                     *                 *
*****
v02.58 (C)Copyright 1985-2008, American Megatrends, Inc.

```

Figure 4: Advanced Settings.

The Advanced page provides:

- ☞ The CPU configuration sub-menu.
- ☞ The IDE configuration sub-menu.
- ☞ The Console Redirection configuration sub-menu.
- ☞ The USB configuration sub-menu.
- ☞ The enable/disable of the LAN.
- ☞ The display of the MAC address.



12.3 CPU Configuration

```

Advanced
* CPU Configuration                               *           Options           *
* *****                                         *           *           *
* Module Version - 00.01                          * Disabled                    *
*                                                  * Enabled                      *
* Manufacturer: DMP                               *                               *
* Brand String: Vortex86DX A9121                 *                               *
* Frequency   : 800MHz                           *                               *
*                                                  *                               *
* L1 Cache           [Enabled]                   *                               *
* Cache L1      : 16 KB                           *                               *
* L2 Cache           [Write-Thru]                *                               *
* Fetch Line Size [4 DWORD]                      *                               *
* Cache L2      : 256 KB                          * **   Select Screen         *
*                                                  * **   Select Item           *
* CPU Speed Setting By [Divide By 1]              * +-   Change Option         *
* CPU Fast Decode Onboard Cycle [Normal]          * F1   General Help          *
*                                                  * F10  Save and Exit         *
*                                                  * ESC  Exit                   *
*                                                  *                               *
* *****                                         *                               *
v02.58 (C)Copyright 1985-2008, American Megatrends, Inc.

```

Figure 5: CPU configuration.

This page displays the information about the CPU.
Some of the CPU configuration can be changed to alter the performances.

- L1 Cache:** allows to enable/disable the Level 1 cache.
- Cache L1:** display the size of the cache level 1.
- L2 Cache:** select the mode of the level 2 cache Write-Thru, Write-Back or disable.
- Fetch Line Size:** select 4 DWORD or 8 DWORD.
- Cache L2:** display the size of the cache level 2.
- CPU Speed Setting By:** allows to slow down the CPU speed.
- CPU Fast Decode Onboard Cycle:** select Normal or Fast.



Tri-M Technologies Inc.
1407 Kebet Way, Unit 100
Port Coquitlam, BC V3C 6L3
Canada

Tel: 800.665.5600, 604.945.9565
Fax: 604.945.9566
E-mail: info@tri-m.com
Web site: www.tri-m.com

12.5 IDE Devices Configuration

```

Advanced
*****
* Primary IDE Master                               * Options *
* ***** *
* Device      :Hard Disk                          * Not Installed *
* Vendor      :ST940813AM                         * Auto *
* Size        :40.0GB                             * CD/DVD *
* LBA Mode    :Supported                          * ARMD *
* Block Mode  :16Sectors                          * *
* PIO Mode    :4                                  * *
* Async DMA   :MultiWord DMA-2                    * *
* Ultra DMA   :Ultra DMA-2                        * *
* S.M.A.R.T. :Supported                            * *
* ***** *
* Type                               [Auto]       * * Select Screen *
* LBA/Large Mode                      [Auto]       * ** Select Item *
* Block (Multi-Sector Transfer)       [Auto]       * +- Change Option *
* PIO Mode                             [Auto]       * F1 General Help *
* DMA Mode                              [Auto]       * F10 Save and Exit *
* S.M.A.R.T.                            [Auto]       * ESC Exit *
* 32Bit Data Transfer                  [Enabled]    * *
* * *
*****
v02.58 (C)Copyright 1985-2008, American Megatrends, Inc.

```

Figure 7: IDE Devices Configuration.

This page displays the specifications of the detected IDE device. Available options will be automatically enable when set on Auto. They can also be manually enabled or disabled.

- Type:** select the type of the device, removable, CDROM, auto or not installed.
- Mode:** LBA or Large.
- Block:** enable or disable the multiple sector transfer.
- PIO Mode:** force the PIO mode from 0 to 4 or use the detected mode.
- DMA Mode:** auto only.
- S.M.A.R.T.:** enable/disable Smart Monitoring, Analysis and Reporting Technology.
- 32bit Data Transfer:** enable/ disable 32bit data transfer.



12.9 PCI/PNP Configuration

```

Main      Advanced  PCIPnP   Boot     Security  Chipset   Exit
*****
* Advanced PCI/PnP Settings                               Options *
* *****
* WARNING: Setting wrong values in below sections      ** No *
*           may cause system to malfunction.           ** Yes *
*                                                         **   *
* Plug & Play O/S                                       [No]   **   *
* PCI Latency Timer                                     [128]  **   *
* Allocate IRQ to PCI VGA                               [No]   **   *
* Palette Snooping                                     [Disabled] **   *
* PCI IDE BusMaster                                    [Enabled] **   *
* OffBoard PCI/ISA IDE Card                            [Auto]  **   *
*                                                         **   *
* IRQ3                                                 [Reserved] **   *
* IRQ4                                                 [Reserved] **   *
* IRQ5                                                 [Available] **   *
* IRQ6                                                 [Available] **   *
* IRQ7                                                 [Available] **   *
* IRQ9                                                 [Available] **   *
* IRQ10                                                [Available] **   *
* IRQ11                                                [Available] **   *
* IRQ12                                                [Available] **   *
* IRQ14                                                [Available] **   *
* IRQ15                                                [Available] **   *
*                                                         **   *
* DMA Channel 0                                       [Available] ** *   Select Screen *
* DMA Channel 1                                       [Available] ** **  Select Item   *
* DMA Channel 3                                       [Available] ** +-  Change Option *
* DMA Channel 5                                       [Available] ** F1  General Help  *
* DMA Channel 6                                       [Available] ** F10 Save and Exit *
* DMA Channel 7                                       [Available] ** ESC  Exit         *
*                                                         **   *
* Reserved Memory Size                                [Disabled] **   *
*****
v02.58 (C)Copyright 1985-2008, American Megatrends, Inc.
*****

```

Figure 11: PCI/PNP Configuration.

PCI / Plug and Play configuration sub menu. It allows to reserve some of the system resources to avoid devices conflict.

Plug & Play O/S: allow the OS to modify the settings for P&P operation.

PCI Latency Timer: set the PCI device latency in number of PCI clocks.

Allocate IRQ to PCI VGA: allow or restrict the system from providing an IRQ for the VGA.

Palette Snooping: allows old PCI capturing card the use the VGA color palette.

PCI IDE BUSMaster: allow/prevent the IDE to be PCI bus master.

Offboard PCI/ISA IDE card: specify the location of an additional off board IDE controller or let the system auto-detect if any present.

IRQ3: reserve the IRQ3 for a legacy ISA device or make it available for PCI/PnP use.



Tri-M Technologies Inc.
 1407 Kebet Way, Unit 100
 Port Coquitlam, BC V3C 6L3
 Canada

Tel: 800.665.5600, 604.945.9565
 Fax: 604.945.9566
 E-mail: info@tri-m.com
 Web site: www.tri-m.com

IRQ4: reserve the IRQ4 for a legacy ISA device or make it available for PCI/PnP use.
IRQ5: reserve the IRQ5 for a legacy ISA device or make it available for PCI/PnP use.
IRQ6: reserve the IRQ6 for a legacy ISA device or make it available for PCI/PnP use.
IRQ7: reserve the IRQ7 for a legacy ISA device or make it available for PCI/PnP use.
IRQ9: reserve the IRQ9 for a legacy ISA device or make it available for PCI/PnP use.
IRQ10: reserve the IRQ10 for a legacy ISA device or make it available for PCI/PnP use.
IRQ11: reserve the IRQ11 for a legacy ISA device or make it available for PCI/PnP use.
IRQ12: reserve the IRQ12 for a legacy ISA device or make it available for PCI/PnP use.
IRQ14: reserve the IRQ14 for a legacy ISA device or make it available for PCI/PnP use.
IRQ15: reserve the IRQ15 for a legacy ISA device or make it available for PCI/PnP use.

DMA Channel 0: reserve the DMA0 for a legacy ISA device or make it available for PCI/PnP use. **DMA Channel 1:** reserve the DMA1 for a legacy ISA device or make it available for PCI/PnP use.
DMA Channel 3: reserve the DMA3 for a legacy ISA device or make it available for PCI/PnP use.
DMA Channel 5: reserve the DMA5 for a legacy ISA device or make it available for PCI/PnP use.
DMA Channel 6: reserve the DMA6 for a legacy ISA device or make it available for PCI/PnP use.
DMA Channel 7: reserve the DMA7 for a legacy ISA device or make it available for PCI/PnP use.

Reserved Memory Size: disable or set the memory size used by ISA devices.



Tri-M Technologies Inc.
1407 Kebet Way, Unit 100
Port Coquitlam, BC V3C 6L3
Canada

Tel: 800.665.5600, 604.945.9565
Fax: 604.945.9566
E-mail: info@tri-m.com
Web site: www.tri-m.com

12.11 Boot Options

```

*****
                          Boot
*****
* Boot Settings Configuration                               *
* *****                                                 *
* Quick Boot [Enabled]                                     *
* Quiet Boot [Disabled]                                   *
* Bootup Num-Lock [On]                                    *
* PS/2 Mouse Support [Auto]                              *
* Boot To OS/2 [No]                                       *
* Interrupt 19 Capture [Enabled]                          *
* Boot From LAN [Disabled]                                *
* Beep Function [Disabled]                                *
* OnBoard Virtual Flash FDD [Disabled]                   *
*
* * * * * Select Screen *
* * * * * Select Item *
* * * * * Change Option *
* * * * * F1 General Help *
* * * * * F10 Save and Exit *
* * * * * ESC Exit *
*
*
*****
v02.58 (C)Copyright 1985-2008, American Megatrends, Inc.

```

Figure 13: Boot Options.

This page allows to configure the startup options.

- Quick Boot:** allow to skip some Power On Self Test (POST) to reduce the boot time.
- Quiet Boot:** allow to display the POST messages or the OEM logo.
- Bootup Num-Lock:** set the the numeric keypad to numeric during the boot up when ON.
- PS/2 Mouse Support:** prevents the PS/2 mouse from using the system resources when disabled.
- Boot To OS/2:** allows to boot the OS/2 operating system.
- Interrupt 19 Capture:** prevent/allow option ROM such as network controllers to trap INT19.
- Boot from LAN:** prevent/ select the LAN boot function.
- Beep Function:** enable/disable the system to generate beep during the boot.
when set the system will generate one beep by USB device detected.
- OnBoard Virtual Flash FDD:** allow to emulate a floppy drive using an SPI flash.



12.15 Security Configuration

```

Main      Advanced  PCIPnP    Boot      Security  Chipset   Exit
*****
* Security Settings                                     *
* *****                                             *
* Supervisor Password :Not Installed                   *
* User Password       :Not Installed                   *
*                                                             *
* Change Supervisor Password                           *
* Change User Password                                 *
*                                                             *
* Boot Sector Virus Protection [Disabled]              *
*                                                             *
*                                                             *
* *          Select Screen                             *
* **         Select Item                               *
* Enter      Change                                    *
* F1         General Help                             *
* F10        Save and Exit                            *
* ESC        Exit                                      *
*                                                             *
*                                                             *
*****
v02.58 (C)Copyright 1985-2008, American Megatrends, Inc.

```

Figure 17: Security Configuration.

The Security Configuration page allows to protect the BIOS setting with a password.

Supervisor Password: show if a supervisor password was created.

User Password: show if a user password was created.

Change Supervisor Password: create/change the supervisor password.

Change User Password: create/change the user password.

The supervisor password grants access to all the BIOS settings where the user password restricts the access to some specific BIOS settings. The restriction to some of the BIOS settings by the user is defined at the BIOS image creation. These restrictions can only be modified on the BIOS image file using the AMIBCP tool.

Boot Sector Virus Protection: prevent/allow write access to the boot sector.



12.20 Serial/Parallel Ports Configuration

```

*****
Chipset
*****
* SB Serial Port 1          [3F8]          * Options          *
*   Serial Port IRQ 1      [IRQ4]          *                 *
*   Serial Port Boud Rate  [115200 BPS]    * Disabled        *
* SB Serial Port 2          [2F8]          * 3F8             *
*   Serial Port IRQ 2      [IRQ3]          * 2F8             *
*   Serial Port Boud Rate  [115200 BPS]    * 3E8             *
* SB Serial Port 3          [3E8]          * 2E8             *
*   Serial Port IRQ 3      [IRQ10]         * 10              *
*   Serial Port Boud Rate  [115200 BPS]    *                 *
* SB Serial Port 4          [2E8]          *                 *
*   Serial Port IRQ 4      [IRQ11]         *                 *
*   Serial Port Boud Rate  [115200 BPS]    *                 *
* SB Parallel Port Address  [378]          * ** Select Screen *
*   Parallel Port Mode     [BPP]          * ** Select Item   *
*   Parallel Port IRQ      [IRQ7]         * +- Change Option *
*                               * F1 General Help  *
*                               * F10 Save and Exit *
*                               * ESC Exit         *
*                               *                 *
*****
v02.58 (C)Copyright 1985-2008, American Megatrends, Inc.

```

Figure 22: Serial/Parallel Ports Configuration.

The Serial/Parallel Ports Configuration page provides the base configuration for the four serial ports and the parallel port.

- SB Serial Port 1:** select the base address for the physical serial port 1.
- Serial Port IRQ 1:** select the interrupt for the physical serial port 1.
- Serial Port Baud Rate:** select the initial baud rate for the physical serial port 1.

- SB Serial Port 2:** select the base address for the physical serial port 2.
- Serial Port IRQ 2:** select the interrupt for the physical serial port 2.
- Serial Port Baud Rate:** select the initial baud rate for the physical serial port 2.

- SB Serial Port 3:** select the base address for the physical serial port 3.
- Serial Port IRQ 3:** select the interrupt for the physical serial port 3.
- Serial Port Baud Rate:** select the initial baud rate for the physical serial port 3.

- SB Serial Port 4:** select the base address for the physical serial port 4.
- Serial Port IRQ 4:** select the interrupt for the physical serial port 4.
- Serial Port Baud Rate:** select the initial baud rate for the physical serial port 4.

- SB Parallel Port Address:** select the base address for the parallel port.
- Serial Port Mode:** select the parallel port mode between, SPP, BPP, EPP and ECP.



Tri-M Technologies Inc.
 1407 Kebet Way, Unit 100
 Port Coquitlam, BC V3C 6L3
 Canada

Tel: 800.665.5600, 604.945.9565
 Fax: 604.945.9566
 E-mail: info@tri-m.com
 Web site: www.tri-m.com

Serial Port IRQ: select the interrupt for the parallel port.

EPP Version: select between EPP compatibility mode 1.7 and 1.9.

ECP Mode DMA Channel: select the DMA channel assigned to the parallel port.



Tri-M Technologies Inc.
1407 Kebet Way, Unit 100
Port Coquitlam, BC V3C 6L3
Canada

Tel: 800.665.5600, 604.945.9565
Fax: 604.945.9566
E-mail: info@tri-m.com
Web site: www.tri-m.com

12.21 Watchdogs Configuration

```

*****
***** Chipset *****
*****
* WatchDog 0 Function      [Enabled]      *          Options          *
*   WatchDog 0 Signal Select [Reset]        *          *                  *
*   WatchDog 0 Timer       [64 Sec]         * 1 Sec                    *
* WatchDog 1 Function      [Enabled]      * 2 Sec                    *
*   WatchDog 1 Signal Select [NMI]         * 4 Sec                    *
*   WatchDog 1 Timer       [16 Sec]        * 8 Sec                    *
*                               * 16 Sec                   *
*                               * 32 Sec                   *
*                               * 64 Sec                   *
*                               * 128 Sec                  *
*                               * 256 Sec                  *
*                               *                            *
* *          Select Screen  *
* **         Select Item   *
* +-         Change Option *
* F1        General Help   *
* F10       Save and Exit  *
* ESC       Exit           *
*                               *
*                               *
*****
v02.58 (C)Copyright 1985-2008, American Megatrends, Inc.

```

Figure 23: Watchdogs Configuration.

The WatchDog Configuration page allows to select the event and the delay for each WatchDog when activated.

WatchDog 0 Function: enable/disable the watchdog timer 0.

WatchDog 0 Signal Select: select the event generated when the watchdog 0 occurs.

WatchDog 0 Timer: set the delay in seconds before the watchdog 0 occurs.

WatchDog 1 Function: enable/disable the watchdog timer 1.

WatchDog 1 Signal Select: select the event generated when the watchdog 1 occurs.

WatchDog 1 Timer: set the delay in seconds before the watchdog 1 occurs.



12.22 Multi-function Ports sub-menu

```

Chipset
*****
* Port0 Function           [GPIO]           **           Options           *
* Port0 Bit0 Direction    [IN]           **           *
* Port0 Bit1 Direction    [IN]           ** GPIO             *
* Port0 Bit2 Direction    [IN]           ** 8051 P0          *
* Port0 Bit3 Direction    [IN]           ** PWM00..PWM07     *
* Port0 Bit4 Direction    [IN]           **           *
* Port0 Bit5 Direction    [IN]           **           *
* Port0 Bit6 Direction    [IN]           **           *
* Port0 Bit7 Direction    [IN]           **           *
* *****
* Port1 Function          [GPIO]           **           *
* Port1 Bit0 Direction    [IN]           **           *
* Port1 Bit1 Direction    [IN]           **           *
* Port1 Bit2 Direction    [IN]           **           *
* Port1 Bit3 Direction    [IN]           **           *
* Port1 Bit4 Direction    [IN]           **           *
* Port1 Bit5 Direction    [IN]           **           *
* Port1 Bit6 Direction    [IN]           **           *
* Port1 Bit7 Direction    [IN]           **           *
* *****
* Port2 Function          [GPIO]           **           *
* Port2 Bit0 Direction    [IN]           **           *
* Port2 Bit1 Direction    [IN]           **           *
* Port2 Bit2 Direction    [IN]           **           *
* Port2 Bit3 Direction    [IN]           **           *
* Port2 Bit4 Direction    [IN]           **           *
* Port2 Bit5 Direction    [IN]           **           *
* Port2 Bit6 Direction    [IN]           **           *
* Port2 Bit7 Direction    [IN]           **           *
* *****
* Port3 Bit0 Function     [SPI]           **           *
* Port3 Bit1 Function     [SPI]           **           *
* Port3 Bit2 Function     [SPI]           **           *
* Port3 Bit3 Function     [SPI]           **           *
* *****
* Port3 Bit4 Function     [I2C]           **           *
* Port3 Bit5 Function     [I2C]           **           *
* *****
* Port3 Bit6 Function     [GPIO]           **           *
* Direction               [IN]           ** **           Select Screen     *
* Port3 Bit7 Function     [GPIO]           ** **           Select Item       *
* Direction               [IN]           ** +-           Change Option     *
* ***** F1             General Help       *
* Port4 Function          [SB Serial Port 1] ** F10          Save and Exit     *
* ***** ESC             Exit               *
* Port5 Function          [SB Serial Port 2] **           *
*****
v02.58 (C)Copyright 1985-2008, American Megatrends, Inc.

```

Figure 24: Multi-function Ports sub-menu.

Port0 Function: select between using the port as GPIO, PWM or GPIO through the internal 8051



Tri-M Technologies Inc.
 1407 Kebet Way, Unit 100
 Port Coquitlam, BC V3C 6L3
 Canada

Tel: 800.665.5600, 604.945.9565
 Fax: 604.945.9566
 E-mail: info@tri-m.com
 Web site: www.tri-m.com

Port0 Bit 0 Direction: select if the pin 1 of connector CN26 is set as input or output.
Output: select if the pin is set to 0 or 1 when assigned as output.

Port0 Bit 1 Direction: select if the pin 2 of connector CN26 is set as input or output.
Output: select if the pin is set to 0 or 1 when assigned as output.

Port0 Bit 2 Direction: select if the pin 3 of connector CN26 is set as input or output.
Output : select if the pin is set to 0 or 1 when assigned as output.

Port0 Bit 3 Direction: select if the pin 4 of connector CN26 is set as input or output.
Output: select if the pin is set to 0 or 1 when assigned as output.

Port0 Bit 4 Direction: select if the pin 5 of connector CN26 is set as input or output.
Output : select if the pin is set to 0 or 1 when assigned as output.

Port0 Bit 5 Direction: select if the pin 6 of connector CN26 is set as input or output.
Output : select if the pin is set to 0 or 1 when assigned as output.

Port0 Bit 6 Direction: select if the pin 7 of connector CN26 is set as input or output.
Output : select if the pin is set to 0 or 1 when assigned as output.

Port0 Bit 7 Direction: select if the pin 8 of connector CN26 is set as input or output.
Output : select if the pin is set to 0 or 1 when assigned as output.



Tri-M Technologies Inc.
1407 Kebet Way, Unit 100
Port Coquitlam, BC V3C 6L3
Canada

Tel: 800.665.5600, 604.945.9565
Fax: 604.945.9566
E-mail: info@tri-m.com
Web site: www.tri-m.com

Port1 Function: must be selected as GPIO

Port1 Bit 0 Direction: set as output to control the transceiver of the serial port 1.
set as input force the factory default.

Output: 0 set the transceiver in power save until valid RS232 level is detected.
1 force the transceiver ON.

Port1 Bit 1 Direction: set as output to control the transceiver of the serial port 2.
set as input force the factory default.

Output: 0 set the transceiver in power save until valid RS232 level is detected.
1 force the transceiver ON.

Port1 Bit 2 Direction: set as output to control the transceiver of the serial port 3.
set as input force the factory default.

Output: 0 set the transceiver in power save until valid RS232 level is detected.
1 force the transceiver ON.

Port1 Bit 3 Direction: set as output to control the transceiver of the serial port 4.
set as input force the factory default.

Output: 0 set the transceiver in power save until valid RS232 level is detected.
1 force the transceiver ON .

Port1 Bit 4 Direction: this setting must be set always as input.

used to read the RS232 transceiver status of the serial port 1.
read 0 when no valid RS232 level applied to any of CN8 inputs.
read 1 when a valid RS232 level is applied to at least one input of CN8.

Port1 Bit 5 Direction: this setting must be set always as input.

used to read the RS232 transceiver status of the serial port 2.
read 0 when no valid RS232 level applied to any of CN9 inputs.
read 1 when a valid RS232 level is applied to at least one input of CN9.

Port1 Bit 6 Direction: this setting must be set always as input.

used to read the RS232 transceiver status of the serial port 3.
read 0 when no valid RS232 level applied to any of CN11 inputs.
read 1 when a valid RS232 level is applied to at least one input of CN11.

Port1 Bit 7 Direction: this setting must be set always as input.

used to read the RS232 transceiver status of the serial port 4.
read 0 when no valid RS232 level applied to any of CN10 inputs.
read 1 when a valid RS232 level is applied to at least one input of CN10.



Port2 Function: must be selected as GPIO

Port2 Bit 0 Direction: set as output to control power switch of the USB port 0.
set as input force the factory default.

Output: 0 turn the power switch of the USB port 0 OFF.
1 turn the power switch of the USB port 0 ON.

Port2 Bit 1 Direction: set as output to control power switch of the USB port 1.
set as input force the factory default.

Output: 0 turn the power switch of the USB port 1 OFF.
1 turn the power switch of the USB port 1 ON.

Port2 Bit 2 Direction: **UNUSED**

Port2 Bit 3 Direction: enable/disable the on-board LEDs.
set as input force the factory default.

Output: 0 enable the on-board LEDs.
1 disable the on-board LEDs

Port2 Bit 4 Direction: this setting must be set always as input.
used to read the power switch status of the USB port 0.
read 0 when the power switch over current flag is set.
read 1 when the power switch is operating normally.

Port2 Bit 5 Direction: this setting must be set always as input.
used to read the power switch status of the USB port 1.
read 0 when the power switch over current flag is set.
read 1 when the power switch is operating normally.

Port2 Bit 6 Direction: select if the SPI port access the on-board SPI flash or SPI connector CN17. set as input force the factory default.

Output: 0 access the on-board SPI flash.
1 access the SPI connector CN17.

Port2 Bit 7 Direction: allow to write protect the on-board Micro-SD.
set as input force the factory default.

Output : 0 allow to write to the Micro-SD.
1 the Micro-SD is write protected.



Port3 Function: can be used as GPIO, SPI and I2C. These features can be combined

Port3 Bit 0 Direction: select if the pin 4 of connector CN17 is set as input or output.

Output: select if the pin is set to 0 or 1 when assigned as output.
feature unavailable when the pin is assigned to the SPI port.

Port3 Bit 1 Direction: select if the pin 3 of connector CN17 is set as input or output.

Output: select if the pin is set to 0 or 1 when assigned as output.
feature unavailable when the pin is assigned to the SPI port.

Port3 Bit 2 Direction: select if the pin 1 of connector CN17 is set as input or output.

Output: select if the pin is set to 0 or 1 when assigned as output.
feature unavailable when the pin is assigned to the SPI port.

Port3 Bit 3 Direction: select if the pin 2 of connector CN17 is set as input or output.

Output: select if the pin is set to 0 or 1 when assigned as output.
feature unavailable when the pin is assigned to the SPI port.

Port3 Bit 4 Direction: select if the pin 2 of connector CN16 is set as input or output.

Output : select if the pin is set to 0 or 1 when assigned as output.
feature unavailable when the pin is assigned to the I²C port.

Port3 Bit 5 Direction: select if the pin 3 of connector CN16 is set as input or output.

Output Value: select if the pin is set to 0 or 1 when assigned as output.
feature unavailable when the pin is assigned to the I²C port.

Port3 Bit 6 Direction: used to detect if the CPU board is powered through the USB device port.

This setting must be set always as input.

Port3 Bit 7 Direction: used by the BIOS to force the Console Redirection On, even when

disable in the BIOS setting.

This setting must be set always as input.



Port4 Function: normally set as Serial Port 1 (COM1).
It can be set as GPIO with limited functionality

Port4 Bit 0 Direction: This setting must be set always as input.
Use to read the RS232 level on connector CN8 pin 1.
read 0 when RS232 level is high.
read 1 when RS232 level is low.
Feature unavailable when the pin is assigned to COM1.

Port4 Bit 1 Direction: This setting must be set always as output.
Output: drive the connector CN8 pin 5 to an RS232 level high or low.
0 drive the RS232 level high.
1 drive the RS232 level low.
Feature unavailable when the pin is assigned to COM1.

Port4 Bit 2 Direction: This setting must be set always as output.
Output : drive the connector CN8 pin 4 to an RS232 level high or low.
0 drive the RS232 level high.
1 drive the RS232 level low.
Feature unavailable when the pin is assigned to COM1.

Port4 Bit 3 Direction: This setting must be set always as input.
Use to read the RS232 level on connector CN8 pin 8.
read 0 when RS232 level is high.
read 1 when RS232 level is low.
Feature unavailable when the pin is assigned to COM1.

Port4 Bit 4 Direction: This setting must be set always as input.
Use to read the RS232 level on connector CN8 pin 3.
read 0 when RS232 level is high.
read 1 when RS232 level is low.
Feature unavailable when the pin is assigned to COM1.

Port4 Bit 5 Direction: This setting must be set always as output.
Output : drive the connector CN8 pin 7 to an RS232 level high or low.
0 drive the RS232 level high.
1 drive the RS232 level low.
Feature unavailable when the pin is assigned to COM1.

Port4 Bit 6 Direction: This setting must be set always as input.
Use to read the RS232 level on connector CN8 pin 2.
read 0 when RS232 level is high.
read 1 when RS232 level is low.
Feature unavailable when the pin is assigned to COM1.



Tri-M Technologies Inc.
1407 Kebet Way, Unit 100
Port Coquitlam, BC V3C 6L3
Canada

Tel: 800.665.5600, 604.945.9565
Fax: 604.945.9566
E-mail: info@tri-m.com
Web site: www.tri-m.com

Port4 Bit 6 Direction: This setting must be set always as input.
Use to read the RS232 level on connector CN8 pin 6.
read 0 when RS232 level is high.
read 1 when RS232 level is low.
Feature unavailable when the pin is assigned to COM1.



There is some limitation to use PORT4 as GPIO because they are wired to the connector CN8 through an RS232 transceiver.



Port5 Function: normally set as Serial Port 2 (COM2).
It can be set as GPIO with limited functionality

Port5 Bit 0 Direction: This setting must be set always as input.
Use to read the RS232 level on connector CN9 pin 1.
read 0 when RS232 level is high.
read 1 when RS232 level is low.
Feature unavailable when the pin is assigned to COM2.

Port5 Bit 1 Direction: This setting must be set always as output.
Output: drive the connector CN9 pin 5 to an RS232 level high or low.
0 drive the RS232 level high.
1 drive the RS232 level low.
Feature unavailable when the pin is assigned to COM2.

Port5 Bit 2 Direction: This setting must be set always as output.
Output : drive the connector CN9 pin 4 to an RS232 level high or low.
0 drive the RS232 level high.
1 drive the RS232 level low.
Feature unavailable when the pin is assigned to COM2.

Port5 Bit 3 Direction: This setting must be set always as input.
Use to read the RS232 level on connector CN9 pin 8.
read 0 when RS232 level is high.
read 1 when RS232 level is low.
Feature unavailable when the pin is assigned to COM2.

Port5 Bit 4 Direction: This setting must be set always as input.
Use to read the RS232 level on connector CN9 pin 3.
read 0 when RS232 level is high.
read 1 when RS232 level is low.
Feature unavailable when the pin is assigned to COM2.

Port5 Bit 5 Direction: This setting must be set always as output.
Output : drive the connector CN9 pin 7 to an RS232 level high or low.
0 drive the RS232 level high.
1 drive the RS232 level low.
Feature unavailable when the pin is assigned to COM2.

Port5 Bit 6 Direction: This setting must be set always as input.
Use to read the RS232 level on connector CN9 pin 2.
read 0 when RS232 level is high.
read 1 when RS232 level is low.
Feature unavailable when the pin is assigned to COM2.



Tri-M Technologies Inc.
1407 Kebet Way, Unit 100
Port Coquitlam, BC V3C 6L3
Canada

Tel: 800.665.5600, 604.945.9565
Fax: 604.945.9566
E-mail: info@tri-m.com
Web site: www.tri-m.com

Port5 Bit 6 Direction: This setting must be set always as input.
Use to read the RS232 level on connector CN9 pin 6.
read 0 when RS232 level is high.
read 1 when RS232 level is low.
Feature unavailable when the pin is assigned to COM2.



There is some limitation to use PORT5 as GPIO because they are wired to the connector CN9 through an RS232 transceiver.



12.23 GPCS Configuration

```

*****
Chipset
*****
* GPCS0 Function          [Enabled]          * Options          *
*   GPCS0 Command        [MEMR/W 8bit]       *                 *
*   GPCS0 Start Address  [000C8000]       * MEMR 8bit       *
*   GPCS0 Mask Compare Bit [FFFFFF000]     * MEMR 16bit      *
* GPCS1 Function          [Enabled]          * MEMW 8bit       *
*   GPCS1 Command        [IOR/W 8bit]       * MEMW 16bit      *
*   GPCS1 Start Address  [00000100]       * MEMR/W 8bit     *
*   GPCS1 Mask Compare Bit [0000FFFE]     * MEMR/W 16bit    *
*                                     * IOR 8bit        *
*                                     * IOR 16bit       *
*                                     * IOW 8bit        *
*                                     *                 *
* *          Select Screen          *
* **         Select Item            *
* +-         Change Option          *
* F1         General Help           *
* F10        Save and Exit          *
* ESC        Exit                    *
*                                     *
*                                     *
*****
v02.58 (C)Copyright 1985-2008, American Megatrends, Inc.

```

Figure 25: GPCS Configuration.

The GPCS Configuration page provides the settings for the two external General Purpose Chip Select.

- GPCS0 Function:** enable/disable the function on the connector CN16 pin 8.
- GPCS0 Command:** select during which operation the chip select is activated.
- GPCS0 Start Address:** define the base address of the chip select.
- GPCS0 Mask Compare Bit:** define the address window where the chip select is active.

- GPCS1 Function:** enable/disable the function on the connector CN16 pin 9.
- GPCS1 Command:** select during which operation the chip select is activated.
- GPCS1 Start Address:** define the base address of the chip select.
- GPCS1 Mask Compare Bit:** define the window size where the chip select is active.



12.24 Redundancy Port Configuration

```

*****
Chipset
*****
* Dual Port 4KB SRAM           [Enabled]           * Options *
* SRAM Command                [MEMR/W 8bit]      *         *
* SRAM Start Address          [000D0000]         * Enabled *
* SRAM Mask Compare Bit       [FFFFFF00]         * Disabled *
* SB Serial Port 9            [Disabled]          *         *
* WatchDog0 Condition         [Disabled]          *         *
* WatchDog1 Condition         [Disabled]          *         *
* Invalid OPCODE Condition    [Disabled]          *         *
* KB/MS System Fail           [Normal]            *         *
* GPIO PORT0 System Fail      [Normal]            *         *
* GPIO PORT1 System Fail      [Normal]            *         *
* GPIO PORT2 System Fail      [Normal]            *         *
* LPT PORT System Fail        [Normal]            * * Select Screen *
* UART1 System Fail           [Normal]            * ** Select Item *
* UART2 System Fail           [Normal]            * +- Change Option *
* UART3 System Fail           [Normal]            * F1 General Help *
* UART4 System Fail           [Normal]            * F10 Save and Exit *
*                               * ESC Exit *
*                               *         *
*                               *         *
*****
v02.58 (C)Copyright 1985-2008, American Megatrends, Inc.

```

Figure 26: Redundancy Port Configuration.

This page allows to configure the communication ports and the fail conditions of the redundancy port. It also allow to define fail state for some devices.

Dual Port 4KB SRAM: enable /disable the internal dual port 4KB SRAM.

SRAM Command: define the access mode of the SRAM.

SRAM Start Address: define the base address of the SRAM.

SRAM Mask Compare Bit: set the windows size of the SRAM used

SB Serial Port 9: set the base address of the serial port 9.

Serial Port IRQ 9: set the interrupt assigned to serial port 9.

WatchDog0 Condition: enable/disable watchdog 0 as fail condition.

WatchDog1 Condition: enable/disable watchdog 1 as fail condition.

Invalid OPCODE Condition: enable/disable an invalid OPCODE as fail condition.



KB/MS System Fail: allows to set both PS/2 ports to tri-state when a failure occurs.

GPIO Port0 System Fail: allows to set the GPIO port 0 to tri-state when a failure occurs.

GPIO Port1 System Fail: allows to set the GPIO port 1 to tri-state when a failure occurs.

GPIO Port2 System Fail: allows to set the GPIO port 2 to tri-state when a failure occurs.

GPIO Port0 System Fail: allows to set the GPIO port 0 to tri-state when a failure occurs.

LPT PORT System Fail: allows to set the parallel port to tri-state when a failure occurs.

UART1 System Fail: allows to set the serial port 1 to tri-state when a failure occurs.

UART2 System Fail: allows to set the serial port 2 to tri-state when a failure occurs.

UART3 System Fail: allows to set the serial port 3 to tri-state when a failure occurs.

UART4 System Fail: allows to set the serial port 4 to tri-state when a failure occurs.



Only the port of the CPU will be tri-stated, these settings do not control the RS232 transceivers. The RS232 transceiver are disabled automatically with the signal SYS-FAIL-OUT.



CHAPTER 12: Literature REFERENCES

The following references are for information about the PC/104 architecture, the PC DOS, and the PC BIOS.

13.1 ISA System Architecture

MindShare, Inc., Tom Shanley and Don Anderson
Internet: mindshar@interserv.com
CompuServe: 72507,1054
Published by Addison Wesley, Inc.

13.2 AT Bus Design

Edward Solari
Anabooks
12145 Alta Carmel Ct., Suite 250
San Diego, CA 92128
ISBN 0-929392-08-6

13.3 Personal Computer Bus Standard P996

Institute of Electrical and Electronic Engineers, Inc.
445 Hoes Lane
Piscataway, NJ 08854

13.4 PC Interrupts

PC Interrupts, Ralf Brown, Addison/Wesley.

13.5 PC/104 Consortium

809 B-175 Cuesta Drive,
Mountain View, CA 94040
Phone: 415 903-8304
FAX: 415 967-0995



Tri-M Technologies Inc.
1407 Kebet Way, Unit 100
Port Coquitlam, BC V3C 6L3
Canada

Tel: 800.665.5600, 604.945.9565
Fax: 604.945.9566
E-mail: info@tri-m.com
Web site: www.tri-m.com